



**IRRIGATION
PRODUCT CATALOG 2021**

WELCOME

Our Vision

Smart and environmentally sustainable irrigation solutions™.

Our Mission

DIG is defined by our commitment to our customers and to developing new environmentally sustainable irrigation solutions. We strive to exceed customer expectations by embracing continuous improvement throughout our organization and our products.

Our Values

DIG is dedicated to the research and development of quality, environmentally conscious irrigation products that support our customers' needs. We are committed to our customers' success and to helping them achieve their goals.

We will proactively develop products of the highest quality in an effort to satisfy global customer needs. We will constantly strive to develop products that use the earth's resources wisely. We will continue to engage in educational opportunities for our customers and employees. We place a high value on integrity and will communicate openly and honestly with our customers and employees.



Customer Satisfaction

Customer satisfaction is the cornerstone of DIG's philosophy. Your success with our products determines the future of our company. We are prepared to help answer your questions through each step of your irrigation projects. We have trained personnel available to give advice when you are developing projects, designing your systems and ordering products.

Sales Team

DIG's professional, experienced sales team is ready to assist you with all of your irrigation needs, from design questions to on-site training. Our knowledgeable salespeople are available to answer questions and make recommendations using DIG products through all stages of your project.

Customer Service

DIG's courteous, knowledgeable customer support department is on hand to provide a personal touch to the order and delivery process. Our goal is to know our customers and fulfill the customer's needs and requirements. From data entry to the moment the product arrives at your door, DIG's customer support is at your service.

Technical Assistance

Technical assistance is just a phone call away. DIG's tech support department is versed not only in the DIG product line, but experienced in most irrigation product lines. Our department is managed by experienced landscape and irrigation experts who understand the need for a quick response and accurate information.

We are ready to assist you at 800-322-9146 or e-mail tech@digcorp.com

Online Technical Information

A wealth of information regarding DIG products is available online at www.digcorp.com. This valuable reference contains online catalogs, CAD details, specifications, programming instructions, instruction manuals, videos, installation guides and part lists, all in an easy-to-access format.

CONTENT

MICRO-LINE™ & EXCEL™ DRIPLINE

MICRO-LINE™ Dripline	2
EXCEL™ Pressure Compensating (PCD) Dripline with Check Valve	3
EXCEL™ Pressure Compensating (PCD) Dripline	5

DISTRIBUTION TUBING

1/8" & 1/4" Vinyl Tubing	8
1/8" & 1/4" Polyethylene Tubing	8
1/2", 3/4" & 1" Polyethylene Tubing	9

DRIP KITS

Home Grow Kit	10
Living Wall Vertical Garden Kit	10

SINGLE & MULTI-OUTLET EMITTERS

TOP 12-Outlet Drip Manifolds	12
6-Outlet PC Drip Manifolds	13
6-Outlet Adjustable Drip Manifold	14
4-Outlet Drip Manifold	14
PC Buttom Drip Emitters	15
Pressure Compensating Emitters on Stake	15
Pressure Compensating Emitters	16
Pressure Compensating Emitters with Built-in Check Valve	16
Button Drip Emitters	17
Flag Drip Emitters	17
Adjustable Drip Emitters	18
Adjustable Bubbler	18

MICRO SPRAYERS & FOGGERS

Dynamic Mini Sprinklers	20
12" Pop-Up Micro Sprayers	21
Assemblies on Stake	21
Fan Spray Jets	22
Vortex Adjustable Sprayer	22
Jet Sprayers	23
A-jets	23
Mist Sprayer on Threaded Barb	24
EXL-Series Foggers	24

SCREEN & DISC FILTERS

3/4" & 1" Plastic Filters with Screen Elements	26
1 1/2" & 2" Plastic Filters with Stainless-Steel Screens	27
2" Heavy-Duty Plastic Screen Filter	28
3/4" - 2" Polyester & Stainless-Steel Filter Screen Elements	28
3/4" & 1" Plastic Filters with Disc Elements	29
1 1/2" & 2" Plastic Filters with Disc Elements	30

FITTINGS & ACCESSORIES

Shut-Off Valves	32
Air Relief Valve	32
Pop-Up Indicators	32
Compression Fittings	33
Universal Fittings	33
1/2" Barbed Fittings	34
1/4" & 1/8" Barbed Fittings	34
Mini In-Line Shut-off Valve	35
Shrub Adapters	35
Hose Ends & Goof Plugs	35
Punches	35
PVC Inserts	35
Threaded Fittings	35
Stakes	36
Pop-Up Riser Assemblies	36
Semi-Rigid PE Riser Assemblies	36

DRIP ZONE & VALVE MANIFOLDS

3/4" & 1" Drip Zone Assemblies	38
Heavy-Duty, Low-to-Medium Flow Preset Pressure Regulators	39
Adjustable Pressure Regulators	40
Pressure Regulating Filters	40

BATTERY POWERED CONTROLLERS AND TIMERS

410BT Bluetooth Controller	42
400A-Series Controller	43
710A-Series Controller	44
7X0A-Series Controllers	45
710AP-Series Controller	46
BOHE-BT Bluetooth® Controller	47
BO9D & BO92A - Hose End Timers	48

AMBIENT LIGHT CONTROLLERS

EVO 100	50
LEIT 2 ET Controller	51
LEIT RC2 ET Handset	52
LEIT 2 ET Weather Station	53
LEIT-1 Ambient Light Powered Controller	54
LEIT 4000	55
LEIT X, LEIT XRC & XRC Handset	57
LEIT Key	59
Switch-Type Sensor Adapter	59
Relay Interface Kit	59
Mounting Columns	60
Stainless-Steel Enclosures	60

SOLENOIDS, VALVES AND ACTUATORS

LEMA 1600HE DC and 160HE DC	62
S-305DC Solenoid	63
Valves/Solenoid Adapters	63
305DC Valves and Actuator	64
Remote Valves	65
24VAC Solenoid	65
24VAC Valves & Actuator	66
24VAC Inline Valves	67
Relay for Battery Operated Controller	68

CHARTS & WARRANTY

Inline & Anti-Siphon Valve Pressure Loss & Specifications	69
Manual Valve Actuator Specifications	69
Conversion Charts, Area Equivalents, & Units of Measure	70
Head Loss Charts	71
Catalogs & Specification Sheets	72
Warranty	72



Whether designing, installing or maintaining an efficient irrigation system, place DIG's EXCEL™ PC CV, EXCEL™ PC and MICRO-LINE™ dripline at the top of your list. Offering new advances in pressure compensating dripline for above or below grade, our EXCEL™ PC CV dripline features a built-in check valve that increases uniformity and conserves water, producing an extended range of dripline for versatility in a wide variety of applications. Both 1/2" and 1/4" dripline contain UV protection and micro filters within each drip emitter to ensure long life and trouble-free operation.

2



MICRO-LINE™ Dripline

3



EXCEL™ Pressure Compensating Dripline with Check Valve

5



EXCEL™ Pressure Compensating (PC) Dripline

6



EXCEL™ PCD Dripline

Features

- Used above ground or under mulch for a variety of applications such as containers and narrow plantings
- Large labyrinth water passage and turbulent flow help reduce clogging
- Inlet filter helps prevent particles from entering the drip emitter labyrinth path
- Resistant to chemicals and fertilizers commonly used in landscape applications
- Used with 1/4" (6 mm) barbed fittings
- Flexible tubing for easy installation
- Two outlets per drip emitter ensure less chance of clogging



Specifications

- Operating pressure: 10-25 PSI (.7-1.7 BAR)
- Flow rates: .52 GPH (1.97 L/H) at 15 PSI (1 BAR)
- Dripline color code: black or brown
- Dripper color code: blue
- Size: 1/4" (.170" ID x .250" OD) (4 mm ID x 6 mm OD)
- Spacing: 6", 9" or 12" (15 cm, 23 cm, or 30 cm)
- Available in 100', 250', 500', 1000' and 3000' coils (30 m, 76 m, 152 m, 305 m and 914 m)
- Minimum bending radius: 1' (30 cm)
- Filter requirement: minimum of 150 mesh
- Materials: polyethylene resin



Flow rate per 50' (15 m) at 15 PSI

Dripper	GPM	GPH	Dripper	LPM	LPH
6"	0.87	52	15 cm	3.29	200
9"	0.58	35	23 cm	2.2	132
12"	0.43	26	30 cm	1.63	98

Flow rate per 50' (15 m) at 20 PSI

Dripper	GPM	GPH	Dripper	LPM	LPH
6"	0.97	58	15 cm	3.67	220
9"	0.64	38	23 cm	2.42	144
12"	0.48	29	30 cm	1.82	110

Flow rate per 50' (15 m) at 25 PSI

Dripper	GPM	GPH	Dripper	LPM	LPH
6"	1.08	65	15 cm	4.09	246
9"	0.72	43	23 cm	2.72	163
12"	0.54	32	30 cm	2.04	121

Maximum recommended length of single lateral

Pressure (BAR)	Flow Rate (GPH)	Dripper Spacing		
		6" (15 cm)	9" (23 cm)	12" (30 cm)
15 PSI (1.0)	.52 (1.97 L/H)	18'	24'	28'
		(5 m)	(7 m)	(9 m)
20 PSI (1.4)	.58 (2.2 L/H)	17'	22'	27'
		(5 m)	(7 m)	(8 m)
25 PSI (1.7)	.65 (2.46 L/H)	16'	21'	27'
		(5 m)	(6 m)	(8 m)

Pressure vs. flow

Pressure (PSI)	Flow (GPH)	Pressure (BAR)	Flow (L/H)
10	0.42	0.7	1.59
15	0.52	1.0	1.97
20	0.58	1.4	2.2
25	0.65	1.7	2.46

Flow rate vs. pressure

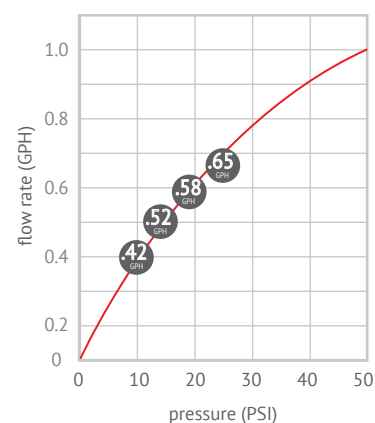

How to specify

Model	Description	Color
ML-1XX	100' .52 GPH	Black
ML-1XXB	100' .52 GPH	Brown
ML-2XX	200' .52 GPH	Black
ML-2XXB	200' .52 GPH	Brown
ML-5XX	500' .52 GPH	Black
ML-5XXB	500' .52 GPH	Brown
ML-10XX	1,000' .52 GPH	Black
ML-10XXB	1,000' .52 GPH	Brown
ML-30XX	3,000' .52 GPH	Black
ML-30XXB	3,000' .52 GPH	Brown

XX = dripper spacing

example:	06	= 6" (15 cm)
ML-1XX	09	= 9" (23 cm)
ML-112	12	= 12" (30 cm)

EXCEL™ PCD CV Dripline with Check Valve

DIG's Excel™ PCD CV Dripline with check valve for subsurface irrigation is a reliable, durable and precise pressure compensating (PC) dripline used for narrow or dense plantings. The dripline's cylindrical drip emitters have built in check valves to prevent siphoning when water pressure drops below 2.5 PSI. This feature protects the inline emitters from sediment, soil particles and debris entering the dripline. Each cylindrical drip emitter's floating diaphragm regulates and maintains a consistent flow rate at variable inlet pressures ranging from 12 to 50 PSI in a wide range of demanding conditions.

Features

- Can be installed above or below grade
- Inline emitter check valve prevents drainage from the dripline when water pressure drops below 2.5 PSI, protecting the emitters against the siphoning of small sediment and soil particles and making it ideal for sub-surface drip installation
- Available in two flow rates, and a wide range of spacings and coil lengths to provide maximum design flexibility in a variety of applications
- Pressure compensating feature provides flow uniformity regardless of pressure variations along the line
- Drip emitter and diaphragm are self-contained units molded to the interior wall of the tubing
- Turbulent flow through a large labyrinth water passage leads water into the flow control chamber where a sensitive floating silicon diaphragm regulates and maintains a constant flow rate at variable inlet pressures. The self-flushing silicon diaphragm allows pressure to build up within the chamber and flush any debris not captured by the intake filter
- Dripline includes one inlet and two outlets per emitter
- Intake inlet has a number of raised grooves that act as a secondary filter; the filter intake area is continuously flushed by water flow through the operation of the system, preventing particles from entering the labyrinth and giving the drip emitter its resistance to clogging
- Check valve and dual, oppositely oriented directional outlets act as a physical barrier to root and debris intrusion

- Resistant to chemicals and fertilizers commonly used in landscaping
- Flexible tubing for easy installation
- Dripline is marked with flow rate and size for easy identification
- Can be used with DIG's 17 mm barb fittings, .700" OD compression fittings and universal Nut Lock™ fittings

Easy to read labels provide a clear description of dripline specifications and spacing



Maximum length of single lateral

Pressure PSI (BAR)	Dripper spacing		
	12" (30 cm)	18" (46 cm)	24" (61 cm)
Flow rate .6 GPH (2.3 L/H)			
15 PSI (1.0)	215' (66 m)	244' (74 m)	370' (113 m)
25 PSI (1.7)	304' (93 m)	406' (124 m)	482' (147 m)
35 PSI (2.4)	343' (105 m)	459' (140 m)	617' (188 m)
45 PSI (3.1)	442' (135 m)	548' (167 m)	772' (235 m)
Flow rate 1.0 GPH (3.8 L/H)			
15 PSI (1.0)	145' (44 m)	221' (67 m)	294' (90 m)
25 PSI (1.7)	185' (56 m)	294' (90 m)	403' (123 m)
35 PSI (2.4)	248' (76 m)	347' (106 m)	479' (146 m)
45 PSI (3.1)	287' (87 m)	413' (126 m)	512' (156 m)

Flow rate per 100' (30 m)

Dripper spacing	Flow rate .6 GPH			
	GPM	L/M	GPH	L/H
12" (30 cm)	1	3.79	60	227
18" (46 cm)	0.67	2.54	40	151
24" (61 cm)	0.50	1.89	30	114
Dripper spacing	Flow rate 1.0 GPH			
	GPM	L/M	GPH	L/H
12" (30 cm)	1.67	6.32	100	379
18" (46 cm)	1.11	4.2	67	254
24" (61 cm)	0.83	3.14	50	189

EXCEL™ PCD CV Dripline with Check Valve

Specifications

- Operating pressure: 12-50 PSI (.8-3.4 BAR)
- Check valve opening pressure: 4.3 PSI (.3 BAR)
- Check valve sealing pressure: 2.5 PSI (.2 BAR)
- Flow rates:
 - .6 GPH (2.3 L/H) color code – orange
 - 1 GPH (3.8 L/H) color code – gray
- Dripline color: brown
- Size: 1/2" (.570" ID x .670" OD) (14.5 mm ID x 17 mm OD)
- Spacing: 12", 18" or 24" (30 cm, 46 cm and 61 cm)
- Available in 100', 250', 500' and 1000' coils (30 m, 76 m, 152 m and 305 m)
- Minimum bending radius: 1' (30 cm)
- Filter requirement: minimum of 150 mesh
- Materials: polyethylene resin

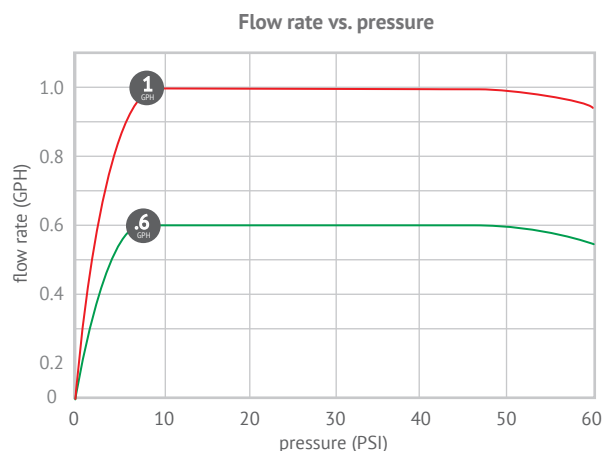

The dripline drip emitter's check valve feature prevents water draining when water pressure drops below 2.5 PSI, protecting the drip emitters from siphoning sediment, soil particles and debris at the end of each irrigation cycle.



How to specify

Model	Description	Color
A5-1XXP-CV	100' .6 GPH	Brown
A1-1XXP-CV	100' 1.0 GPH	Brown
A5-2XXP-CV	250' .6 GPH	Brown
A1-2XXP-CV	250' 1.0 GPH	Brown
A5-5XXP-CV	500' .6 GPH	Brown
A1-5XXP-CV	500' 1.0 GPH	Brown
A5-XXP-CV	1,000' .6 GPH	Brown
A1-XXP-CV	1,000' 1.0 GPH	Brown

XX = dripper spacing

example:
 A5-5XXP-CV
 ↓↓
 A5-512P-CV

12	= 12" (30 cm)
18	= 18" (46 cm)
24	= 24" (61 cm)

EXCEL™ PCD Pressure Compensating (PC) Dripline

Excel™ PCD with .670 OD (17 mm) Pressure Compensating (PC) Dripline is a precise pressure compensating dripline with dual outlets. The inserted cylindrical drip emitters are designed with floating diaphragms to regulate and maintain a consistent flow rate at variable inlet pressures between 12 to 50 PSI.

Features

- Available in black or brown with .570" or .600" ID (17 or 18 mm)
- Dual outlets maintain proper flow from opposite sides regardless of dripline layout direction
- Superior burst strength, flexibility and environmental stress-cracking resistance
- Flow regulated, self-flushing inline drip emitters deliver equal flow at a wide range of operating pressures
- Two flow rates provide maximum flexibility on a variety of applications
- Turbulent flow through a large labyrinth water passage helps reduce clogging
- Continuous self-flushing during irrigation ensures consistent operation
- Two outlets per emitter form a physical barrier to root and debris intrusion
- Floating diaphragm regulates and maintains an even flow at variable inlet pressures
- Drip emitter is made of three individual sections including a labyrinth passage, cylindrical plastic housing, a plastic receptacle and a floating silicon diaphragm
- Resistant to chemicals and fertilizers commonly used in landscaping
- Flexible tubing for easy installation
- The dripline is marked with flow rate, size and date for easy identification
- Can be used with DIG's 17 mm barb fittings, .700" OD compression fittings and universal Nut Lock™ fittings

Specifications

- Operating pressure: 12-50 PSI (.8-3.4 BAR)
- Flow rates:
 - .58 GPH (2.2 L/H) color code - yellow
 - .95 GPH (3.6 L/H) color code - white
- Color code: black or brown
- Sizes:
 - .570" ID x .670" OD (14.5 mm ID x 17 mm OD)
- Spacing: 12", 18", 24", 30" and 36" (30 cm, 46 cm, 61 cm, 76 cm and 91 cm)
- Lengths: 100', 250', 500' and 1000' coils (30 m, 76 m, 152 m and 305 m)
- Minimum bending radius: 1' (30 cm)
- Filter requirement: minimum of 150 mesh
- Materials: polyethylene resin

Easy to read labels provide a clear description of dripline specifications and spacing



How to specify

Model	Description	Color
PCD Dripline .670" OD (17 mm)		
A5-1XXP	100' .58 GPH	Brown
A1-1XXP	100' .95 GPH	Brown
A5-2XXP	250' .95 GPH	Brown
A1-2XXP	250' .95 GPH	Brown
A5-5XXP	500' .58 GPH	Brown
A1-5XXP	500' .95 GPH	Brown
A5-XXP	1000' .58 GPH	Brown
A1-XXP	1000' .95 GPH	Brown

XX = dripper spacing

example:	12 = 12" (30 cm)
A5-5XXP	18 = 18" (46 cm)
	↓ ↓
A5-512P	24 = 24" (61 cm)
	30 = 30" (76 cm)

EXCEL™ PCD Pressure Compensating (PC) Dripline

Excel™ PCD Dripline with .700 OD (18 mm) offers excellent performance at a range of operating pressures and presents many advantages in site preservation and system efficiency, supporting trouble-free operation and a long life. Unlike most other driplines with just one outlet per dripper, DIG's PCD drip line emitters have dual auxiliary outlets on opposing sides, assuring continuous discharge from each drip emitter along the line for maximum plugging protection.

Dual auxiliary outlets on opposing sides, assuring continuous discharge from each drip emitter along the line



Flow rate vs. pressure

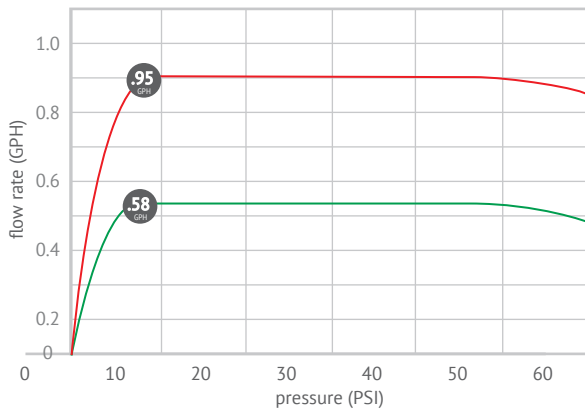

How to specify

Model	Description	Color
PCD Dripline .700" OD (18 mm)		
A5-1XXB	100' .58 GPH	Black
A1-1XXB	100' .95 GPH	Black
A5-2XXB	250' .95 GPH	Black
A1-2XXB	250' .95 GPH	Black
A5-5XXB	500' .58 GPH	Black
A1-5XXB	500' .95 GPH	Black
A5-XXB	1000' .58 GPH	Black
A1-XXB	1000' .95 GPH	Black

Maximum length of single lateral 18 mm PCD dripline

Pressure PSI (BAR)	Dripper spacing		
	12" (30 cm)	18" (46 cm)	24" (61 cm)
Flow rate .58 GPH (2.2 L/H)			
15 PSI (1.0)	238' (73 m)	299' (91 m)	396' (120 m)
25 PSI (1.7)	335' (102 m)	468' (142 m)	609' (185 m)
35 PSI (2.4)	396' (120 m)	564' (171 m)	736' (224 m)
45 PSI (3.2)	487' (148 m)	644' (196 m)	820' (249 m)
Flow rate .95 GPH (3.6 L/H)			
15 PSI (1.0)	190' (58 m)	232' (70 m)	328' (100 m)
25 PSI (1.7)	244' (74 m)	364' (111 m)	438' (133 m)
35 PSI (2.4)	309' (94 m)	432' (131 m)	537' (163 m)
45 PSI (3.2)	340' (103 m)	498' (151 m)	584' (178 m)

Maximum length of single lateral 17 mm PCD dripline

Pressure PSI (BAR)	Dripper spacing		
	12" (30 cm)	18" (46 cm)	24" (61 cm)
Flow rate .58 GPH (2.2 L/H)			
15 PSI (1.0)	218' (66 m)	281' (86 m)	376' (115 m)
25 PSI (1.7)	320' (98 m)	446' (136 m)	587' (179 m)
35 PSI (2.4)	376' (115 m)	545' (166 m)	706' (215 m)
45 PSI (3.2)	465' (142 m)	624' (190 m)	792' (241 m)
Flow rate .95 GPH (3.6 L/H)			
15 PSI (1.0)	172' (52 m)	221' (67 m)	300' (91 m)
25 PSI (1.7)	231' (70 m)	347' (105 m)	419' (127 m)
35 PSI (2.4)	297' (90 m)	409' (124 m)	512' (155 m)
45 PSI (3.2)	330' (100 m)	479' (145 m)	561' (170 m)

Flow rate per 100' (30 m)

Dripper spacing	Flow rate .58 GPH (2.2 L/H)			
	GPM	L/M	GPH	L/H
12" (30 cm)	0.97	3.67	58	220
18" (46 cm)	0.64	2.42	39	148
24" (61 cm)	0.48	1.82	29	110
30" (76 cm)	0.39	1.48	23	87
Dripper spacing	Flow rate .95 GPH (3.6 L/H)			
	GPM	L/M	GPH	L/H
12" (30 cm)	1.58	5.98	95	360
18" (46 cm)	1.06	4.01	63	240
24" (61 cm)	0.79	2.99	48	182
30" (76 cm)	0.63	2.38	38	144

Distribution Tubing



DIG extrudes its polyethylene tubing at our Vista manufacturing facility, producing over 100 million feet each year. A minimum of 2% carbon black is added to ensure maximum UV protection.

Our polyethylene drip tubing is available in a wide range of sizes and coil lengths, including 1/8" and 1/4" distribution tubing.

In vinyl tubing, DIG offers both 1/8" and 1/4" distribution tubing in lengths from 100' up to 3,000' on spooled coils. Made of a high-quality vinyl material, it is UV resistant and can be used in a variety of applications.

- Compact uniform coils for ease of shipping and storage
- Five-year limited manufacturer warranty



8

1/8" & 1/4" Vinyl Tubing



8

1/8" & 1/4"
Polyethylene Tubing



9

1/2", 3/4" & 1"
Polyethylene Tubing

1/8" & 1/4" Vinyl Tubing

Features

- 1/8" used with TOP 12-outlet emitters
- UV resistant
- Made of high-quality material
- 500', 1000' and 3000' coils (152 m, 305 m and 914 m) coiled on cardboard cores

Specifications

- Operating pressure: up to 30 PSI (2.1 BAR)
- Available in multiple configurations:
 - 1/8": .118" ID x .187" OD
 - 1/4": .156" ID x .245" OD
 - 1/4": .160" ID x .220" OD
 - 1/4": .170" ID x .250" OD
- Stiffness: 90 shore
- Material: vinyl



How to specify		
Model	Description	Color
1/8" Vinyl		
12-006	100' • .118" ID x .187" OD	Black
12-042	500' • .118" ID x .187" OD	Black
12-043	1000' • .118" ID x .187" OD	Black
1/4" Vinyl		
12-003	50' • .156" ID x .245" OD	Black
12-030	50' • .156" ID x .245" OD	Tan
12-002	100' • .156" ID x .245" OD	Brown
12-049	500' • .156" ID x .245" OD	Brown
12-013	100' • .156" ID x .245" OD	Black
12-005	500' • .156" ID x .245" OD	Black
12-050	1000' • .156" ID x .245" OD	Black
12-015	3000' • .156" ID x .245" OD	Black
12-055	100' • .160" ID x .220" OD	Black
12-056	500' • .160" ID x .220" OD	Black
12-057	1000' • .160" ID x .220" OD	Black
12-125	25' • .170" ID x .250" OD	Black
12-109	50' • .170" ID x .250" OD	Black
12-110	100' • .170" ID x .250" OD	Black
12-111	500' • .170" ID x .250" OD	Black
12-112	1000' • .170" ID x .250" OD	Black
12-118	1000' • .160" ID x .270" OD	Black

1/8" & 1/4" Polyethylene Tubing

Features

- Blank polyethylene distribution tubing available in 50', 100', 500', 1000' and 3000' coils (30 m, 152 m, 305 m and 914 m)
- 500', 1000' and 3000' coils (152 m, 305 m and 914 m) coiled on cardboard cores

Specifications

- Operating pressure: up to 60 PSI (4.1 BAR)
- Available in three configurations:
 - .125" ID x .187" OD (3.2 x 4.7 mm)
 - .160" ID x .220" OD (4.1 x 5.6 mm)
 - .170" ID x .250" OD (4.3 x 6.4 mm)
- Material: linear low-density polyethylene resin



How to specify		
Model	Description	Color
1/8" Poly tubing		
12-036	100' • .125" ID x .187" OD	Black
12-075	500' • .125" ID x .187" OD	Black
12-080	1000' • .125" ID x .187" OD	Black
12-085	3000' • .125" ID x .187" OD	Black
1/4" Poly tubing		
12-038	100' • .170" ID x .250" OD	Black
12-041	500' • .170" ID x .250" OD	Black
12-060	1000' • .170" ID x .250" OD	Black
12-065	3000' • .170" ID x .250" OD	Black

Distribution Tubing

1/2", 3/4" & 1" Polyethylene Tubing

Features

- Contains antioxidants to protect the drip tubing from thermal degradation; minimum of 2% concentrated carbon black resin added
- Polyethylene drip tubing exhibits a combination of outstanding environmental stress-cracking resistance and burst strength
- Can be used with our wide range of compression and barbed fittings
- Available in black or brown colors
- Coil lengths in 50', 100', 250', 500' and 1000' (15 m, 30 m, 76 m, 152 m and 305 m)



Specifications

- Operating pressure: up to 60 PSI (4.2 BAR)
- Available in six configurations:
 - .520" ID x .620" OD (13.2 mm x 15.7 mm) wall thickness: .050" (1.3 mm)
 - .570" ID" x .670" OD (14.5 mm x 17.0 mm) wall thickness: .050" (1.3 mm)
 - .600" ID x .700" OD (15.2 mm x 17.8 mm) wall thickness: .050" (1.3 mm)
 - .620" ID x .710" OD (15.7 mm x 18.0 mm) wall thickness: .045" (1.1 mm)
 - .820" ID x .940" OD (20.8 mm x 23.9 mm) wall thickness: .060" (1.5 mm)
 - 1.060" ID x 1.200" OD (26.9 mm x 30.5 mm) wall thickness: .070" (1.8 mm)
- Material: polyethylene resin

How to specify

Model	Description	Color
1/2" Poly tubing		
31-004	50' • .530" ID x .630" OD	Black
31-005	100' • .530" ID x .630" OD	Black
31-006	200' • .530" ID x .630" OD	Black
31-007	500' • .530" ID x .630" OD	Black
31-008	1000' • .530" ID x .630" OD	Black
31-009	50' • .620" ID x .710" OD	Black
31-010	100' • .620" ID x .710" OD	Black
31-011	200' • .620" ID x .710" OD	Black
31-012	500' • .620" ID x .710" OD	Black
31-013	1000' • .620" ID x .710" OD	Black
31-016B	100' • .570" ID x .670" OD	Brown
31-017B	250' • .570" ID x .670" OD	Brown
31-018B	500' • .570" ID x .670" OD	Brown
3/4" Poly tubing		
14-000	250' • .820" ID x .940" OD	Black
14-002	500' • .820" ID x .940" OD	Black
1" Poly tubing		
14-011	250' • 1.06" ID x 1.20" OD	Black
14-012	500' • 1.06" ID x 1.20" OD	Black

Home Grow Kit

Features

- Pressure regulated, self-flushing drip emitters with a built-in check valve attached at the end of the micro tubing stop dripping when water pressure drops below 2.2 PSI
- Can be installed in any position
- Unaffected by fluctuating inlet water pressure
- No special tools or glue are needed
- Eight plugs provide a means of closing the eight outlets

Specifications

- Manifold inlet: 1/2" FNPT
- Manifold outlet: 12 outlets to fit 1/4" converter bars
- Mini disc filter: 60 mesh
- Operating pressure range: 10 to 50 PSI
- Required opening pressure: 4.3 PSI
- Closing pressure: 2.2 PSI
- Flow rate per outlet: 1 GPH (3.8 L/H); color brown/black
- Micro tubing length and size: 100' x 1/4"



- Inlet size: 1/4" barb
- Outlet side: 1/8" barb
- Material: high-impact plastic and silicone diaphragms

How to specify

Model	Description
21-233	GRWKIT-12

Living Wall Kit

Features

- Convenient modular wall mounting brackets allow the pots to be hung and removed from the wall very easily
- Mounting brackets can be secured to each other with a simple self-lock position for quick and easy installation and kit expansion
- Pots can easily be mounted, removed, re-planted and re-mounted again for very convenient system installation
- Water line from the Living Wall™ vertical garden kit can be connected into the water supply household faucet or garden hose



Specifications

- Small pot size: 4 3/4" (12.1 cm) width x 5 1/2" (14 cm) depth x 6 1/2" (16.5 cm) height
- Large pot size: 6 7/8" (17.5 cm) width x 6 7/8" (17.5 cm) depth x 6 1/2" (16.5 cm) height
- Pot color: grey
- The irrigation kit is expandable up to 65 pots using 1/4" (6 mm) micro tubing as the main line. If larger, the main line needs to be 1/2" (16 or 17 mm).

How to specify

Model	Description
GLW08	Living Wall Kit with eight pots
70-007	Additional wall mounting brackets
70-009S	Small pot assembly with bottom mesh plate
70-010L	Large pot assembly with bottom mesh plate
GLW-DE5	Drip expansion accessories

Single & Multi-Outlet Drip Emitters



There are many types of drip emitters to consider when designing a drip irrigation layout for your landscape. DIG's full array of drip emitters can meet all of your low-flow irrigation needs.

From our PC multi-outlet drip manifolds, designed for both first time installations and for retrofitting an existing sprinkler system, to our single-point pressure compensating drip emitters for use in long laterals, our range of drip emitters provides plenty of options for any design requirements.



12

TOP 12-Outlet PC Manifolds



13

6-Outlet PC Manifolds



14

4-Outlet PC Manifolds



15

Pressure Compensating Drip Emitters and Stakes



16

Pressure Compensating Emitters



17

Button Drip Emitters



17

Flag Drip Emitters



18

Adjustable Drip Emitters



18

Adjustable Bubbler

TOP – 12-Outlet PC Drip Manifolds

Features

- Constructed with 12 individually pressure compensating drip emitters
- Self-flushing emitters allow passage of water and minimize clogging
- Interchangeable drip emitters for variable flow rates in a single head
- Color-coded drip emitters and barbs easily identify flow rate at each zone
- Drip emitters are individually filtered (approx. 80 mesh)
- Backup mini disc filter included
- Rugged materials to withstand the most adverse conditions
- Can be installed above grade or placed below grade in a 6" emitter box
- Inlet plugs provide the option to cap off up to eight drip emitters
- TOP kits contains 100' of 1/8" distribution tubing, accessories, stakes and 1/4" converter barbs which allow the use of 1/4" distribution tubing

Specifications

- Recommended operating pressure: 15-50 PSI (1-3.4 BAR)
- Pressure compensating range: 8-80 PSI (.5-5.6 BAR)
- Flow rates: .6, 1, 2.2 and 3.3 GPH (2.3, 3.8, 8.3 and 12.5 L/H)
- Inlet size: 1/2" FNPT
- Used with 1/8" (.187" OD) or 1/4" (.150"-.160" ID) distribution tubing
- Filter requirement: minimum of 120 mesh
- Materials:
 - Body and cover: high-impact plastic
 - Filter: nylon
 - Diaphragm: silicon

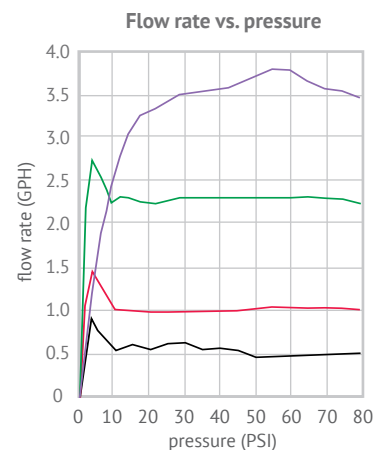

Dimensions

- Dimensions: 3" W x 2" H (8 cm W x 5 cm H)

Performance					
Maximum number of TOP on single length of PVC lateral					
Color	Black	Red	Green	Purple	
Flow in GPH	.6 GPH	1 GPH	2.2 GPH	3.3 GPH	
Number of manifolds	Total flow rate in GPM				
1	0.12	0.2	0.44	0.66	
5	0.6	1	2.2	3.3	
10	1.2	2	4.4	6.6	
15	1.8	3	6.6	9.9	
20	2.4	4	8.8	13.2	
25	3.0	5	11.0	16.5	
30	3.6	6	13.2	19.8	
35	4.2	7	15.4	23.1	
40	4.8	8	17.6	26.4	
45	5.4	9	19.8	29.7	
50	6.0	10	22.0	33.0	

Emitter Conditions

During Self Flushing Mode

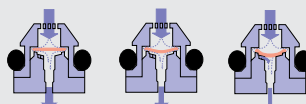

0-3 PSI

3-8 PSI

8-80 PSI

The TOP concept consists of self-cleaning pressure compensating emitters with the ability to compensate for pressure fluctuations between 8-80 PSI, achieved through the utilization of a silicone diaphragm and the water passage design. The self-flushing function works between 0-8 PSI and is achieved as follows:

At 0-3 PSI, the flow is relatively high and the emitter is in flushing mode, while the diaphragm is completely open.

As the pressure increases between 3-8 PSI, the diaphragm slowly begins to close; flow is still high, but steadily decreasing. The diaphragm is closed between 8-80 PSI, and the flow is constant.

Opening and closing the system will bring the TOP to a flushing mode.

How to specify

Model	Description
TOP-000	Manifold only
TOP-005	.6 GPH per outlet
TOP-010	1 GPH per outlet
TOP-020	2.2 GPH per outlet
TOP-030	3.3 GPH per outlet
TOP-100	KIT with 1 GPH per outlet
TOP-200	KIT with 2.2 GPH per outlet
TOP-300	KIT with 3.3 GPH per outlet
Replacement drip emitter with O-ring	
10-019	.6 GPH per outlet
10-020	1 GPH per outlet
10-021	2.2 GPH per outlet
10-022	3.3 GPH per outlet
10-016	Bug plug for 1/8" micro tubing
25-007	Converter elbow for 1/4" micro tubing

6-Outlet Adjustable PC Drip Manifold

6-Outlet Adjustable PC Drip Manifold

Features

- Swivel barbed outlets allow installation flexibility and protection of flow control
- Made of rugged materials to withstand adverse conditions
- Can be installed above or below grade in a 6" (15 cm) emitter box
- Used with 1/4" (.150"-.160" ID) (4 mm ID) distribution tubing or with 1/4" (6 mm) dripline

Specifications

- Operating pressure: 15-50 PSI (1-3.4 BAR)
- Flow rate is adjustable between 0-20 GPH (0-76 L/H) per each outlet
- Inlet size: 1/2" FNPT
- Outlet size: press-fit flow dial with a 1/4" barb
- Filter requirement: min. of 80 mesh

Dimensions

- 2.25" W x 1.5" H (5.7 cm W x 3.8 cm H)



How to specify

Model	Description
06-620	Barb outlet, 1/2" FPT, adjustable head, 0-20 GPH per outlet



6-Outlet PC Drip Manifold

Features

- Available in two flow rates
- Large water passages with rolling diaphragm allow debris to pass through without clogging
- Individual flow-regulated devices for each outlet
- Rugged materials to withstand adverse conditions
- Can be installed above grade or placed below grade in a 6" emitter box
- Available with barbs or barbed elbow outlets to hold 1/4" distribution tubing

Dimensions

- 2.25" W x 1.5" H
(5.7 cm W x 3.8 cm H)

Specifications

- Operating pressure: 15-50 PSI (1-3.4 BAR)

- Flow rates: 4.5 and 5.5 GPH (17 and 20.8 L/H)
- Inlet size: 1/2" FNPT
- Outlet size: 1/4" barb or barbed elbow
- Used with 1/4" (.150"-.160" ID) distribution tubing
- Filter requirement: min. of 80 mesh
- Materials:
 - Body, covers and flow regulating device: high-impact plastic
 - Diaphragms: silicon
 - Barbed outlets: acetal



How to specify

Model	Description	Color
With side outlet		
06-504	4.5 GPH	Black
06-506	5.5 GPH	Green
06-508	8.2 GPH	Blue
With straight outlet		
06-608	8.2 GPH	Blue
06-604	4.5 GPH	Black

Flow rate vs. pressure

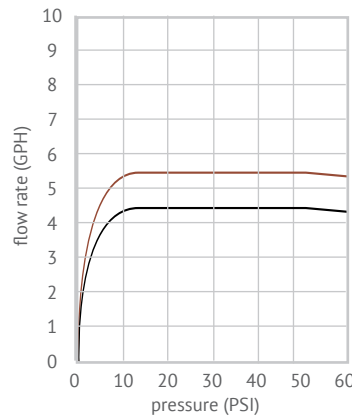

Performance total flow rate per drip head

Drip heads	Flow per outlet		Flow per outlet	
	4.5 GPH	0.7 GPM	5.5 GPH	0.9 GPM
1	27	0.45	33	0.55
5	135	2.25	165	2.75
10	270	4.50	330	5.50
15	405	6.75	495	8.25
20	540	9.00	660	11.0

4-Outlet PC Drip Manifolds

Features

- Built with a large water passage and backup screen filter to help prevent clogging
- Available with top-mounted, barbed connector outlets, which can be easily removed or replaced to hold 1/4" distribution tubing
- Four flow rates, color-coded for easy identification
- Constructed of UV-resistant, durable plastic material to withstand the most adverse conditions
- Can be installed above grade or placed below grade in a 6" emitter box

Dimensions

- 1.3" W x 2.3" H (3.3 cm W x 5.8 cm H)

Specifications

- Operating pressure: 10-50 PSI (.7-3.4 BAR)
- Flow rates: 2, 6, 12, and 20 GPH (8, 23, 45, and 76 L/H)
- Inlet size: 1/2" FNPT
- Outlet size: 1/4" (6 mm) barb
- Filter requirement: minimum of 120 mesh
- Materials:
 - Body: ABS
 - Diaphragm: EPDM



How to specify

Model	Description	Color
06-042	2 GPH	Blue
06-043	6 GPH	Black
06-044	12 GPH	Red
06-045	20 GPH	Green

APEX™ Pressure Compensating Online Drip Emitters

Pressure Compensating Button Drip Emitters



Features

- Ideal watering solution for long laterals, rapid irrigation cycles, and for light soils
- Turbulent flow through a large labyrinth water passage helps reduce clogging
- Self-flushing mechanism provides excellent clog resistance
- Even uniformity from each emitter at a pressure range of 7.25 to 58 PSI
- Colored outlet cover enables easy identification of dripper flow rate
- Outlet can be connected into 1/8" micro tubing with a stake for branching from the main line or lateral
- Unaffected by fluctuating inlet water pressure

Specifications

- Operating pressure: 7.25-58 PSI (.5 - 4 BAR)
- Flow rates and color codes:
 - .5 GPH (1.78 L/H) color code brown
 - 1 GPH (4 L/H) color code black
 - 2 GPH (7.60 L/H) color code green
 - 4 GPH (15.5 L/H) color code red
- Inlet size: 1/4" (4 mm) barb
- Outlet size: 1/4" nipple
- Filter requirement:
 - 120 mesh/130 micron for .58 GPH (2.2 L/H) or lower
 - 150 mesh/100 micron for 1 GPH (3.8 L/H) or higher
 Filter selection depends on water quality and concentration of dirt particles
- Materials:
 - Body and cover: polypropylene
 - Diaphragm: silicone



How to specify

Model	Description	Color
PCO-005	.5 GPH	Brown
PCO-010	1 GPH	Black
PCO-020	2 GPH	Green
PCO-040	4 GPH	Red

Flow rate vs. pressure

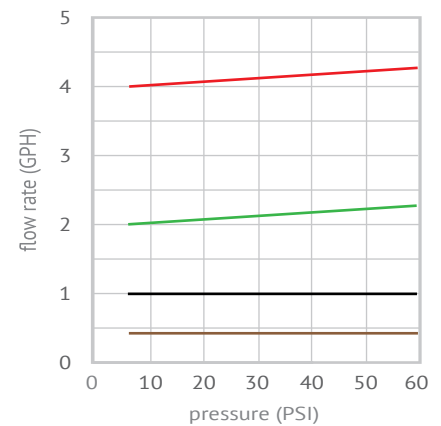

Pressure Compensating Drip Emitters Stakes

Features

- Turbulent flow path
- Constructed of UV-resistant, durable plastic material to withstand the most adverse conditions
- Available in two color-coded flow rates for easy identification
- Pressure compensation enables the use of longer laterals with smaller-diameter tubing

- Flow rates: 1 and 2 GPH (4 and 8 L/H)
- Inlet size: 1/4" (4 mm) barb
- Outlet size: .2" (5.1 mm)
- Stake height: 5" (13 cm)
- Filter requirement: minimum of 150 mesh
- Materials:
 - Body and cover: polypropylene
 - Diaphragm: silicone



How to specify

Model	Description	Color
06-054	1-GPH button dripper 6" stake	Black
06-055	2-GPH button dripper 6" stake	Green

Dimensions

- .95" W x 1" H (2.4 cm W x 2.5 cm H)

Specifications

- Recommended operating pressure: 15-40 PSI (1-2.8 BAR)

Pressure Compensating Emitters with Built-in Check Valve

Pressure Compensating Drip Emitters with Built-in Check Valve

Features

- Ideal watering solution for long laterals, pulse irrigation and light soil, including boxes and containers
- Check valve provides consistent flow and reduces lateral filling time, supporting water savings
- Colored barbed-cap outlet enables easy identification of dripper flow rate
- Barb outlet can be configured to work with 1/8" or 1/4" micro tubing for branching from the dripper
- Unaffected by fluctuating inlet water pressure
- Composed of superior materials for a long life

Specifications

- Operating pressure: 10-50 PSI (.7-3.4 BAR)
- Required opening pressure: 4.3 PSI (.3 BAR)
- Closing pressure: 2.2 PSI (.2 BAR)
- Flow rates and color codes:
 - .3 GPH (1.1 L/H) color code gray
 - .58 GPH (2.2 L/H) color code brown
 - 1 GPH (3.8 L/H) color code black
- Inlet size: 1/4" barb
- Outlet size: 1/8" barb
- Filter requirement:
 - 120 mesh for .58 GPH (2.2 L/H) or lower
 - 150 mesh for 1 GPH (3.8 L/H) or higher



- Material:
 - Body and cover: polypropylene
 - Diaphragm: silicon

How to specify

Model	Description	Color
PCA-003 CV	.3-GPH dripper	Gray
PCA-006 CV	.58-GPH dripper	Brown
PCA-010 CV	1-GPH dripper	Black

Pressure Compensating Drip Emitters

Features

- Barbed inlet for installation into drip tubing or 1/4" distribution tubing
- Male nipple outlet for placement of a multi-outlet adapter or bug caps
- Constructed of UV-resistant, durable plastic material
- Available in three color-coded flow rates for easy identification
- Pressure compensation enables the use of longer laterals with smaller-diameter tubing

Specifications

- Operating pressure: 10-45 PSI (.7-3.1 BAR)
- Flow rates: 1, 2, and 4 GPH (4, 8 and 15 L/H)
- Inlet size: 1/4" (4 mm) barb
- Outlet size: .2" (5.1 mm) male nipple
- Outlet length: .35" (8.9 mm)
- Filter requirement: minimum of 150 mesh
- Materials:
 - Body and cover: ABS
 - Diaphragm: silicone



How to specify

Model	Description	Color
06-014	1-GPH button dripper	Black
06-015	2-GPH button dripper	Green
06-016	4-GPH button dripper	Red

Flow rate vs. pressure

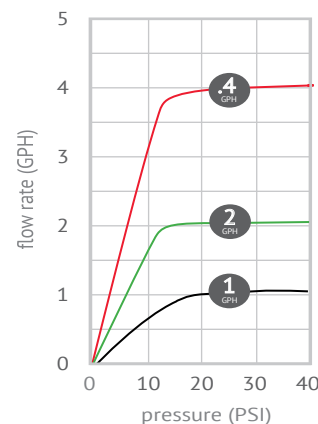

Button & Flag Drip Emitters

Button Drip Emitters

Features

- Unique design with a minimum width passage of 0.043" that supports a turbulent flow to prevent clogging
- Uniform flow rate
- Constructed of high-quality material to ensure stability and long life
- Twist-open design for easy cleaning

Maximum length of single lateral

Color	Flow rate GPH	Dripper spacing Inch	Pipe diameter		
			.520" ID	.600" ID	.830" ID
Brown	0.5	18	258'	345'	649'
		24	306'	405'	785'
		36	429'	563'	1025'
		42	476'	626'	1133'
Black	1.0	18	163'	219'	413'
		24	204'	270'	501'
		36	273'	360'	653'
		42	304'	399'	710'
Green	2.0	18	103'	139'	265'
		24	130'	172'	321'
		36	174'	228'	420'
		42	192'	255'	465'

Specifications

- Operating pressure: 10-25 PSI (.7-1.7 BAR)
- Flow rates and color codes:
 - .5 GPH (2 L/H) color code – brown
 - 1 GPH (4 L/H) color code – black
 - 2 GPH (8 L/H) color code – green
- Available on a 1/4" barb
- Filter requirement: minimum of 150 mesh
- Materials: polypropylene



How to specify

Model	Description	Color
06-019	0.5 GPH	Brown
06-020	1.0 GPH	Black
06-021	2.0 GPH	Green

BD-Tool

- Removal and open to clean tool



Flow rate vs. pressure

PSI	0.5 GPH dripper	1.0 GPH dripper	2.0 GPH dripper
15	0.55	1.09	2.18
20	0.63	1.25	2.51
25	0.70	1.40	2.80

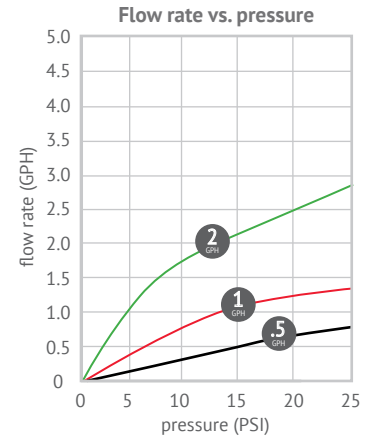

Flag Drip Emitters

Features

- Tapered barbed inlet for easy installation
- Outlet barb for use with 1/4" (.150"-.160" ID) distribution tubing
- Twist-open top with lock for secure operation under pressure and easy cleaning (with locking feature)
- Durable high-impact plastic

Specifications

- Operating pressure: 10-20 PSI (.7-1.4 BAR)
- Flow rates and color codes:
 - 1 GPH (4 L/H) color code – black
 - 2 GPH (8 L/H) color code – green
 - 4 GPH (15 L/H) color code – red

- 2 GPH (8 L/H) color code – green
- 4 GPH (15 L/H) color code – red
- Filter requirement: minimum of 150 mesh

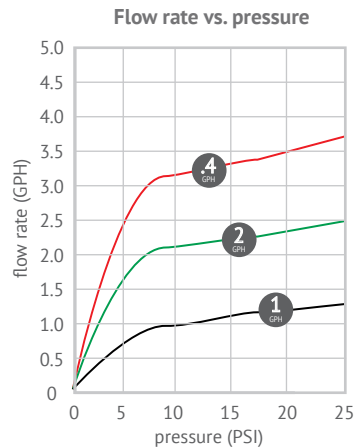

How to specify

Model	Description	Color
06-009	1 GPH with 1/4" barb	Black
06-010	2 GPH with 1/4" barb	Green
06-007	4 GPH with 1/4" barb	Red

Adjustable Drip Emitters

Features

- Can be taken apart for easy cleaning
- UV-stabilized material for long life
- Click adjustment from flow off to full flow – perfect as the plant grows and its need for water changes
- Constructed of UV-resistant, durable plastic material to withstand the most adverse conditions
- Self-tapping barbed inlet for easy installation

Specifications

- Operating pressure: 15-30 PSI (1-2.1 BAR)
- Flow rates and color codes:
 - Adjustable from 0-15.7 GPH (0-59.4 L/H)
 - Color code: black
- 180° or 360° coverage
- Available on a 1/4" barb or 5" (13 cm) stake with a barb
- Filter requirement: minimum of 150 mesh

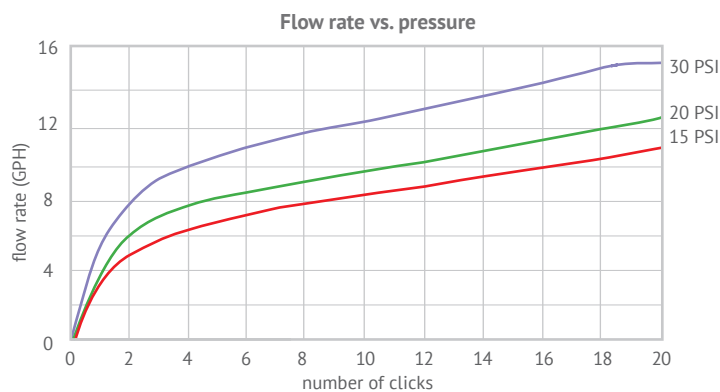

How to specify

Model	Description	Color
06-011	0-10 GPH 360° on barb	Black
06-012	0-10 GPH 360° on stake	Black
06-002	0-10 GPH 180° on barb	Black
06-003	0-10 GPH 180° on stake	Black

Performance

	Pressure (PSI)	Flow (GPH)	Throw dia. (FT)
Fully open (approx. 14 clicks)	15	0-11	0-1.5
	20	0-12.5	0-1.9
	30	0-15.7	0-2.7

Adjustable Bubbler

Features

- High volume, direct watering of plants
- Can be taken apart for easy cleaning
- Click adjustment from flow off to full flow – perfect as the plant grows and its need for water changes
- UV-stabilized material for long life

Specifications

- Operating pressure: 15-30 PSI (1-2.1 BAR)
- Flow rates and color codes:
 - Adjustable from 0-32 GPH (0-121 L/H)
 - 360° coverage
 - Color code: black
- Available on a 1/4" barb or 5" (13 cm) stake with barb
- Filter requirement: minimum of 150 mesh

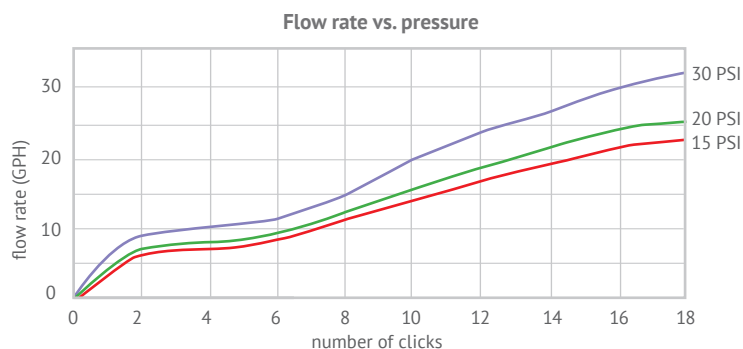

How to specify

Model	Description	Color
06-033	0-30 GPH 360° on barb	Black
06-034	0-30 GPH 360° on stake	Black

Performance

	Pressure (PSI)	Flow (GPH)	Throw dia. (FT)
Fully open (approx. 18 clicks)	15	0-22.7	0-1.6
	20	0-25.8	0-2.6
	30	0-32.0	0-3.5

Micro Sprayers & Foggers



When your design requirements include a range of wetting patterns with low precipitation rates, DIG offers a complete line of spray jets, pop-ups, micro sprayers and foggers with multiple features to choose from.

The EXL-Series foggers are ideal for misting and cooling applications. Their vortex-flow design, which spins the water droplets into a fine mist, can result in lower ambient temperatures for better control of a plants' environment.

20



Dynamic Mini Sprinklers

21



12" Pop-Up Micro Sprayers

21



Pop-Up Riser Assemblies

22



Fan Spray Jets

22



Vortex Adjustable Sprayer

23



Jet Sprayers

23



A-Jets

24



Mist Sprayer

24



EXL-Series Foggers

Dynamic Mini Sprinklers

Features

- Excellent performance with uniform water distribution
- Press-fit configuration for easy maintenance
- Head closes downwards after operation to prevent dirt and insects from entering the sprinkler (insect-proof)
- Dynamic operation ensures self-cleaning and prevents accumulation of deposits
- Firm construction gives a complete 360° circle
- Available on 1/2" FNPT base or completely assembled on a spike with micro tubing

Specifications

- Recommended operating pressure: 25 - 35 PSI (1.7 - 2.4 BAR)
- Recommended operating pressure: 35 PSI (2.4 BAR)
- Flow rates: 10 - 42 GPH (38 L/H - 159 L/H)
- Diameter of coverage: 10' - 17' (3 - 5 m)
- Material: polyacetal



Flow rate vs. pressure

Model number	52-700-10	52-700-15	52-700-18	52-700-24	52-700-27	52-700-32	52-700-42
Nozzle color	Silver	Gray	Black	Green	Dk. Blue	Red	Brown
Nominal flow rate at 30 PSI (2.1 BAR)							
Flow rates (GPH)	10	15	18	24	27	32	42
Wetting diameter (feet)	10	11	13	14	15	16	17

Performance & technical data reverted at 6' (1.8 m) height

Nozzle color	Silver	Gray	Black	Green	Dk. Blue	Red	Brown
Performance at 30 PSI (2.1 BAR)							
Flow rates (GPH)	10.9	16.3	19.0	24.4	28.5	32.6	43.4
Wetting diameter (feet)	7	11	12	14	16	15	16

How to specify

Model	Description	Color
52-700-10	10 GPH 360°	Lt. Blue
52-700-15	15 GPH 360°	Gray
52-700-18	18 GPH 360°	Black
52-700-24	24 GPH 360°	Green
52-700-27	27 GPH 360°	Dk. Blue
52-700-32	32 GPH 360°	Red
52-700-42	42 GPH 360°	Brown
52-700-0	Stake assembly for mini sprinkler	

Pop-Up Micro Sprayers

12" Pop-Up Micro Sprayers

Features

- 12" pop-up lengths with a 1/4" (6 mm) barbed elbow or 1/2" MNPT
- Unique design incorporates a pressure-activated, low-friction, upper-stem seal
- Second-stage piston seal ensures sealing
- Can be used with all sizes of polyethylene tubing using the 1/4" barbed elbow option
- Three color-coded spray nozzles for easy identification
- Constructed of UV-resistant, durable plastic material to withstand the most adverse conditions
- Filter requirement: minimum of 150 mesh

Specifications

- Operating pressure: 15-30 PSI (1-2.1 BAR)
- Nominal operating pressure: 30 PSI (2.1 BAR)
- Flow rate: .15-.73 GPM (34-166 L/H)
- Wetting diameter: up to 12.5' (3.8 m)
- Filter requirement: 120 mesh
- Inlet size: 1/2" MNPT thread or 1/4" barbed side outlet
- Materials:
 - Body and piston: semi-rigid polypropylene
 - Seals: EPDM and vinyl
 - Base: high-impact plastic
 - Spring: stainless-steel 304

Dimensions

- Pop-up height: 12" (30 cm) or when up 21" (53 cm)



MNPT inlet

Barbed inlet

How to specify

Model	Description
1/2" MNPT inlet with 12" pop-up	
MP-121	90° spray head
MP-122	180° spray head
MP-123	360° spray head
1/4" Barbed inlet with 12" pop-up	
MP-124	90° spray head
MP-125	180° spray head
MP-126	360° spray head

Performance flow rate vs. pressure			
Pressure (PSI)	Flow rate (GPH)	Flow rate (GPM)	Throw
360° Spray • nozzle color: RED • orifice size 0.08"			
15	31.5	0.53	10.6' diameter
20	36.2	0.60	11.3' diameter
25	40.3	0.67	11.9' diameter
30	44.0	0.73	12.5' diameter
180° Spray • nozzle color: GREEN • orifice size 0.06"			
15	16.4	0.27	5.1' radius
20	19.0	0.32	5.5' radius
25	21.3	0.36	5.8' radius
30	23.3	0.39	6.1' radius
90° Spray • nozzle color: BLUE • orifice size 0.03"			
15	6.2	0.10	3.3' radius
20	7.3	0.12	3.5' radius
25	8.1	0.14	3.7' radius
30	8.9	0.15	3.9' radius

Pop-Up Riser Assemblies

Features

- Available in 8" or 12" with 1/2" MNPT or with a 1/4" barb
- Unique design incorporates a pressure-activated, low-friction, upper-stem seal and a second-stage piston seal to ensure positive sealing
- 1/4" side outlet can be used

with 1/4" (.150"-.170" ID) distribution tubing and installed on any polyethylene tubing

Specifications

- Operating pressure: 15-35 PSI (1-2.4 BAR)
- Filter requirement: 120 mesh

Dimensions

- 8" (20 cm) or, when up, 13" (33 cm)
- 12" (30 cm) or, when up, 21" (53 cm)



How to specify

Model	Description
16-508	8" pop-up riser with 1/4" barb
16-509	12" pop-up riser with 1/4" barb
16-510	8" pop-up riser with 1/2" MNPT
16-511	12" pop-up riser with 1/2" MNPT

Fan Spray Jets

Features

- Easy to install using the quick thread base and wide wing edges
- Stake assembly includes a 12" thick-walled poly distribution riser with .300" OD
- Used with 1/4" (.150"-.160" ID) distribution tubing
- Three color-coded nozzles for easy identification
- Constructed of UV-resistant, durable plastic material to withstand the most adverse conditions

Specifications

- Operating pressure: 15-30 PSI (1-2.1 BAR)
- Nominal operating pressure: 30 PSI (2.1 BAR)
- Flow rate: 6-44 GPH (23-167 l/h)
- Wetting diameter: up to 12.5' (3.8 m)
- Orifice size: .03"-.08"
- Filter requirement: 120 mesh



How to specify

Model	Description	Color
Fan spray jet head		
07-080	90°	Blue
07-081	180°	Green
07-082	360°	Red
Fan spray jet on spike assembly		
07-080-1	90°	Blue
07-081-1	180°	Green
07-082-1	360°	Red

Vortex Adjustable Sprayer

Features

- Comes with a stake, barb and 10-32" thread
- Adjustable full-circle vortex sprayer with fine water droplets
- Easy to install using attached barb with extra wide wings
- Used with 1/4" distribution tubing (.150"-.160" ID)
- Adjustable flow, including shut-off
- Removable cap for easy cleaning
- Trajectory: 100°
- Fully open: approximately 22 clicks
- Filter requirement: minimum of 120 mesh

Flow rate vs. pressure

Pressure (PSI)	Flow (GPH)	Flow (GPM)	Radius (FT)
15	0-14	0.23	0-5.8
20	0-16	0.27	0-7.8
25	0-20	0.33	0-11.5

*With sprayer a minimum of 5" above ground



How to specify

Model	Description
07-005	360° on a 6" stake
07-035	360° on barb
07-036	360° on 10/32" thread

Micro Jet Sprayers

Jet Sprayers

Features

- Color-coded heads signify various spray patterns
- Available on a stake assembly with 24" vinyl distribution tubing or a threaded barb
- Used with 1/4" distribution tubing (.150"-.160" ID)
- Removable cap for easy cleaning
- Constructed of UV-resistant, durable plastic material



Flow rate vs. pressure

Pressure (PSI)	Flow (GPH)	360°	180°	90°
		Diameter (FT)	Radius (FT)	Radius (FT)
15	10.5	15.2	5.9	6.6
20	12.0	16.9	6.4	7.6
25	13.4	18.4	6.9	8.5
30	14.7	19.8	7.3	9.3

*With sprayer a minimum of 8" above ground

How to specify

Spray pattern:	90°	180°	360°
Assembly color:	Blue/Blk	Blue/Blue	Blue/Red
10/32 Thread	07-001	07-002	07-003
Stake Assembly	07-025	07-024	07-023

Specifications

- Operating pressure: 15-30 PSI (1-2.1 BAR)
- Flow rates: 14 GPH (53 L/H)
- Wetting diameter: up to 20' (6.1 m)
- Pattern: 360°, 180°, 90° and strip
- Nozzle size: .04"
- Filter requirement: minimum of 120 mesh

A-Jets

Features

- Mini valve can be adjusted to reduce flow and diameter
- Available in three spray patterns
- Available on 10-32 thread or completely assembled with a spike and 12" PE riser with a barb; no moving parts
- Constructed of UV-resistant, durable plastic material.



Flow rate vs. pressure

Pressure (PSI)	Flow (GPH)	360°	180°	90°
		Diameter (FT)	Radius (FT)	Radius (FT)
10	0-16.7	0-17	0-7.2	0-5.7
15	0-20.3	0-18	0-8.2	0-7.0
20	0-23.4	0-20	0-9.1	0-8.1
25	0-26.1	0-22	0-9.9	0-9.0
30	0-28.6	0-23	0-10.6	0-9.9

*With sprayer a minimum of 13" above ground

How to specify

Model	Description
07-061	360° on 10-32 thread
07-062	180° on 10-32 thread
07-063	90° on 10-32 thread
MA-136	360° on spike assembly
MA-118	180° on spike assembly
MA-109	90° on spike assembly

Mist Sprayer on Threaded Barb

Features

- Projects a fine mist
- Flat trajectory
- Vortex mechanism allows for a larger water passage to prevent clogging
- Constructed of UV-resistant plastic material

Specifications

- Flow rates: 6.7-7.6 GPH (25.4-28.7 L/H)
- Operating pressure: 30-50 PSI (2-3.5 BAR)
- Wetting diameter: 5.4'-7.2' (1.7 m-2.2 m)
- Pattern: 360°
- Nozzle size: 0.51"
- Filter requirement: 120 mesh



How to specify

Model	Description
07-006	360° on 10-32 thread

EXL-Series Foggers

Features

- Incorporates a vortex design which swirls water droplets into a fine mist
- Modular, lightweight and easy to maintain, configure and install
- Designed without a bridge to prevent dripping
- Three-part construction with an O-ring for a tight seal
- Available on 1/2" FNPT, a 1/4" barb or 10-32 thread

Specifications

- Operating pressure: 35-80 PSI (2.4-5.6 BAR)
- Nominal flow rates 50 PSI (3.5 BAR)
- Flow rate: .8-3 GPH (3-11.6 L/H)
- Inlet size: 1/4" (6 mm) barb or 10-32 thread
- Filter requirement: minimum of 200 mesh
- Materials:
 - Body: acetal
 - O-ring: Buna-N



How to specify

Model	Description	Color
Fogger assembly with tan body and cover		
07-044	0.8 GPH with barb	Purple
07-045	1.0 GPH with barb	Black
07-046	1.5 GPH with barb	Green
07-052	2.0 GPH with barb	Brown
07-047	0.8 GPH on 10/32 thread	Purple
07-048	1.0 GPH on 10/32 thread	Black
07-058	1.5 GPH on 10/32 thread	Green
07-059	2 GPH on 10/32 thread	Brown
07-054	3.0 GPH on 10/32 thread	Gray
Fogger assembly with back body and cover		
07-048	1.0 GPH on 10/32 thread	Black
07-051	1 GPH on 10/32 thread	Black
07-053	2 GPH on 10/32 thread	Brown
07-054	3.0 GPH on 10/32 thread	Gray

Dimensions

- 1.3" W x 2.3" H (3.3 cm W x 5.8 mm H)

Flow rate vs. pressure

Nozzle color	Purple	Black	Green	Brown	Gray
Nozzle size (IN)	0.010	0.013	0.020	0.025	0.035
Flow rate	0.8	1.0	1.5	2.0	3.0
Diameter (FT)	2.5	2.5	33.5	3.5	4.0
Misting angle	70°	70°	70°	70°	70°
Flow rates (GPH)					
35 PSI	0.76	0.85	1.36	1.68	2.40
40 PSI	0.80	0.91	1.49	1.85	2.61
45 PSI	0.84	0.98	1.52	1.91	2.78
50 PSI	0.85	1.04	1.58	2.02	2.91
55 PSI	0.87	1.07	1.64	2.09	3.02
60 PSI	0.90	1.14	1.71	2.18	3.17
65 PSI	0.91	1.17	1.74	2.26	3.25
70 PSI	1.01	1.26	1.81	2.31	3.42



How to specify

Model	Description	Color
07-049	0.8 GPH w/ 1/4" barbed elbow	Purple
07-050	1.0 GPH w/ 1/4" barbed elbow	Black
07-055	1.5 GPH w/ 1/4" barbed elbow	Green
07-056	2.0 GPH w/ 1/4" barbed elbow	Brown
07-057	3.0 GPH w/ 1/4" barbed elbow	Gray
07-101	1.5 GPH on 1/2" FNPT	Green
07-102	2.0 GPH on 1/2" FNPT	Brown
07-103	3.0 GPH on 1/2" FNPT	Gray

Screen & Disc Filters



Gray water, recycled water, reclaimed water, non-potable water—the sources of today’s water supplies are becoming more diverse. To ensure that both low-volume irrigation and high-tech landscape irrigation systems operate efficiently, it is now more important than ever to install the correct type and size of filter to protect the irrigation system.

That’s why DIG provides a complete range of professional-grade, high-performance disc and screen filters, all engineered to provide clean water from a variety of water supply sources, and to keep the irrigation systems operating efficiently year after year.



26

3/4" & 1" Plastic Filters with Screen Elements



27

1½" & 2" Plastic Filters with Stainless-Steel Screens



28

2" Heavy-Duty Plastic Screen Filter



28

3/4" – 2" Polyester & Stainless-Steel Filter Screen Elements



29

3/4" & 1" Plastic Filters with Disc Elements



30

1½" & 2" Plastic Filters with Disc Elements

3/4" & 1" Plastic Filters with Screen Elements

3/4" & 1" Plastic Filters with Screen Elements

Features

- All-purpose filter with a wide range of polyester and stainless-steel screens from 80 to 200 mesh to suit a wide range of filtration requirements
- Screens have excellent resistance to most common chemicals
- Color-coded replacement screens for easy identification
- Large filter area and low friction loss allow long intervals between cleaning
- Available with a flush cap or flush valve for easy flushing of particles trapped in the bottom of the filter
- Recommended to be installed and used after the control valve
- Easy maintenance – the screen can be extracted from the filter for easy cleaning
- Interchangeable screen and disc elements
- Constructed of UV-resistant, durable plastic material to withstand the most adverse conditions

Specifications

- Operating pressure: up to 120 PSI (8.3 BAR)
- Flow rates: up to 18 GPM (4 m³/h)
- Inlet and outlet size: 3/4" FHT x MHT and 3/4" or 1" MNPT
- Temperature range: up to 130°F (54°C)
- Stainless steel and polyester screens from 80 to 200 mesh



How to specify

Model	Description
P09-XXX	3/4" FHT x MHT w/poly screen & flush cap
P10-XXX	3/4" MNPT w/poly screen & flush cap
P11-XXX	3/4" MNPT w/SS screen & flush cap
P12-XXX	3/4" MNPT w/poly screen & flush valve
P13-XXX	3/4" MNPT w/SS screen & flush valve
P14-XXX	3/4" FHT x MHT w/SS screen & flush cap
P15-XXX	3/4" FHT x MHT w/SS screen & flush valve
P16-XXX	1" MNPT w/poly screen & flush cap
P17-XXX	1" MNPT w/SS screen & flush cap
P19-XXX	1" MNPT w/SS screen & flush valve

XXX = Filter mesh

example:	040-40	mesh
P10-XXX	080-80	mesh
	120-120	mesh
	155-155	mesh
P10-155	200-200	mesh

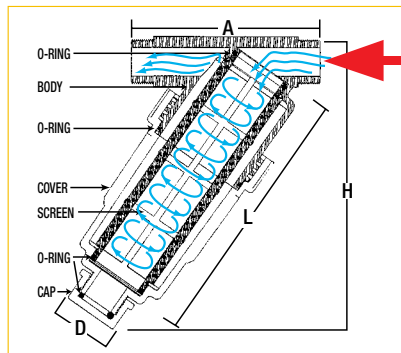
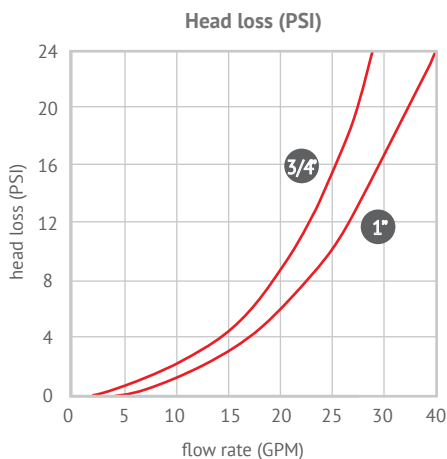

Dimension and weight

Size	A		B		C		D		WT lbs
	in	mm	in	mm	in	mm	in	mm	
3/4" with cap	4.71	120	1.5	38	6	152	7	177	.457
1" with cap	4.74	120	1.5	38	6	152	7	177	.457
3/4" w/flush valve	4.71	120	1.5	38	6	152	8	203	.489
1" w/flush valve	4.74	120	1.5	38	6	152	8	203	.489

Surface area & flow rate

Size	Filtration surface area		Maximum recommended flow rates			
	in	mm	sq. in	cm ²	GPM	m ³ /h
3/4	20		14.9	96	13	3
1	25		14.9	96	18	5

1½" & 2" Plastic Filters with Stainless-Steel Screens

1½" & 2" Plastic Filters with Stainless-Steel Screens

Features

- Large filter area and low friction loss allow long intervals between cleaning
- All-purpose filter with a wide range of stainless-steel screens from 80 to 180 microns to suit a wide range of filtration requirements
- Designed to reduce operating costs and deliver high-quality filtrate in a minimum space
- Screens have excellent resistance to most common chemicals
- Easy maintenance – the screen can be extracted from the filter for cleaning
- Interchangeable screen and disc elements
- Access point on the inlet and outlet side for pressure measurement test
- Constructed of UV-resistant, durable plastic material to withstand the most adverse conditions

Specifications

- Operating pressure: up to 120 PSI (8.3 BAR)
- Flow rates: up to 80 GPM (18.1 m³/h)
- Temperature range: up to 130°F (54°C)
- Inlet and outlet size: 1 1/2" and 2" MNPT
- Stainless-steel screens from 80 to 200 mesh



Filter Materials

- Housing: polypropylene
- O-ring: EPDM
- Pressure testing port: polypropylene
- Pressure testing seals: natural rubber BR

How to specify

Model	Description
P75-XXXL	1 1/2" MNPT with SS screen & flush cap
P80-XXXL	2" MNPT with SS screen & flush cap
XXX = Screen filter mesh	
example:	080-80 mesh
P10-XXXL	120-120 mesh
↓↓↓	155-155 mesh
P80-200L	200-200 mesh
Filter cover tool	
17-034	to open and remove the 1 1/2" and 2" cover

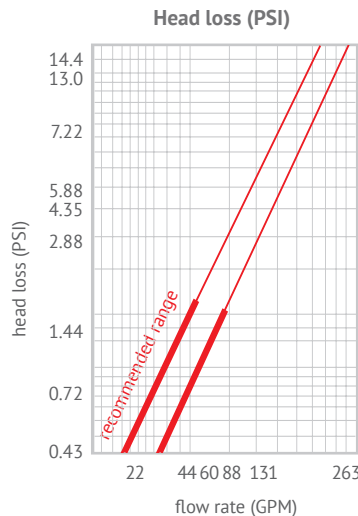
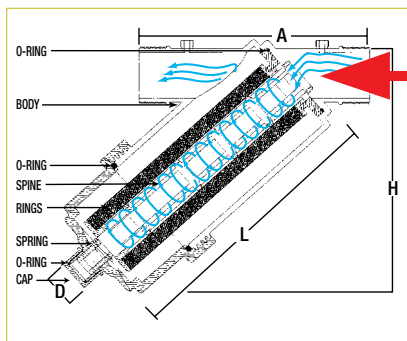

Dimensions & weight

Size	A		B		C		D		WT
	in	mm	in	mm	in	mm	in	mm	lbs
1 1/2"	10.1	257	3.1	80	8.6	220	9.4	240	2.3
2"	10.1	257	3.1	80	10.4	265	10.6	270	2.6

Surface area & flow rate

Size	Filtration surface area		Maximum recommended flow rates			
	in	mm	sq. in	cm ²	GPM	m ³ /h
1 1/2"	38	85.6	552	60	15	
2"	50	103.8	670	80	20	

2" Heavy-Duty Plastic Screen Filter

Features

- Special swivel-locking ring enables easy opening of the filter's lid without the use of tools.
- Wide range of filtration degrees up to 200 mesh
- Large filter area and low friction loss allow long intervals between cleaning
- Designed to reduce operating costs and deliver high-quality filtrate in a minimum space
- Access point on the inlet and outlet side for pressure measurement test
- Constructed of UV-resistant, durable plastic material to withstand the most adverse conditions

Specifications

- Flow rates: up to 110 GPM (25 m)
- Screen filtration area: 147 inch² (948 cm²)
- Operating pressure: up to 150 PSI (10.3 BAR)
- Temperature range: up to 140°F (60°C)
- Inlet and outlet size: 2" MNPT (5.1 cm)
- Filter Materials:
 - Housing and cover: PP and G
 - Locking ring: PA and GF
 - O-ring: EPDM
 - Screen spine: PP and stainless steel
 - Pressure testing port: polypropylene
 - Pressure testing seals: natural rubber BR How



How to specify

Model	Description
PN2MPT-200	200-mesh stainless-steel screen
PN2MPT-155	155-mesh stainless-steel screen
PN2TMPT-200	200-mesh stainless-steel screen
PN2TMPT-155	155-mesh stainless-steel screen
17-SSM-200	200-mesh stainless-steel screen
17-SSM-155	155-mesh stainless-steel screen

3/4" – 2" Polyester & Stainless-Steel Filter Screen Elements

Features

- Screens can retain large amounts of sediment that accumulate on the inside surface
- Screens can be easily removed for maintenance
- Color-coded screens for easy identification and replacement

Chemical Resistance

- Excellent resistance to most mineral acids
- Limited resistance to alkali depending on concentration and temperature
- Excellent resistance to low concentration of lye

Screen Materials

- Cylinder: polyester
- Screen: polyester or stainless steel
- O-ring: EPDM



Filtration degree & material

Filter screen elements			
Mesh	Micron	Material	Color
80	180	Stainless steel	Blue
120	130	Stainless steel	Brown
155	100	Stainless steel	Green
200	80	Stainless steel	Burgundy
40	400	Polyester	Navy blue
80	180	Polyester	Blue
120	130	Polyester	Brown
155	100	Polyester	Green
200	80	Polyester	Burgundy

How to specify

Model	Description	Color
3/4" & 1" filter screen elements		
17-401	40-mesh polyester screen	Navy blue
17-402	80-mesh polyester screen	Blue
17-403	120-mesh polyester screen	Brown
17-404	155-mesh polyester screen	Green
17-405	200-mesh polyester screen	Burgundy
17-412	80-mesh stainless-steel screen	Blue
17-413	120-mesh stainless-steel screen	Brown
17-414	155-mesh stainless-steel screen	Green
17-415	200-mesh stainless-steel screen	Burgundy

How to specify

Model	Description	Color
1 1/2" & 2" filter screen elements		
17-080L	80-mesh SS • 1 1/2" long	Blue
17-120L	120-mesh SS • 1 1/2" long	Brown
17-155L	155-mesh SS • 1 1/2" long	Green
17-200L	200-mesh SS • 1 1/2" long	Burgundy
17-085	80-mesh SS • 2" long	Blue
17-125	120-mesh SS • 2" long	Brown
17-160	155-mesh SS • 2" long	Green
17-205	200-mesh SS • 2" long	Burgundy

3/4" & 1" Plastic Filters with Disc Elements

3/4" & 1" Plastic Filters with Disc Elements

Features

- Disc filters consist of a body, cover and grooved disc cylinders stacked on a plastic spine, forming a cylindrical filter element. The discs are compressed together inside the filter housing by a spring located at the bottom of the filter cover to provide three-dimensional filtration
- Sediments accumulate on the outer face of the stacked discs, allowing clean water to flow through the discs and out the middle of the filter
- Disc elements provide in-depth filtration to retain organic matter
- During operation, the disc elements are tightly pressed together by pressure and the spring, providing high filtration efficiency
- Discs have excellent resistance to most common chemicals
- Easy maintenance – the discs can be extracted for cleaning
- Interchangeable color-coded discs and stainless-steel screen elements provide a wide range of filtration degrees and options
- Constructed of UV-resistant, durable plastic material to withstand the most adverse conditions

Filter and Disc Materials

- Housing and discs: polypropylene
- O-ring: EPDM
- Pressure testing ports: polypropylene
- Pressure testing seals: natural rubber BR
- Disc cylinder assembly: polypropylene / PBT
- Spring: stainless steel 304



Specifications

- Operating pressure: up to 120 PSI (8.4 BAR)
- Flow rates: 3/4" & 1": up to 18 GPM (4 m³/h)
- Temperature range: up to 130°F (54°C)
- Inlet and outlet size: 3/4" and 1" MNPT

Filtration degree & material

Mesh	Micron	Material	Color
80	180	Polypropylene	Yellow
120	130	Polypropylene	Red
150	100	Polypropylene	Black

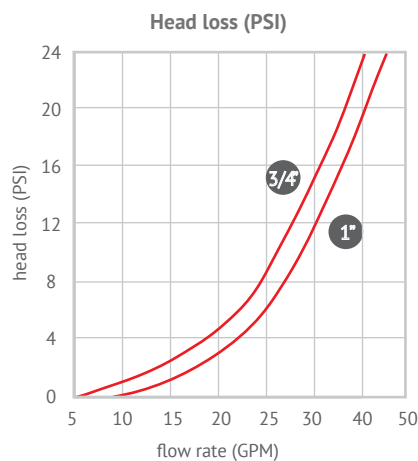

Dimension & weight

Size	A		B		C		D		WT
	in	mm	in	mm	in	mm	in	mm	lbs
3/4"	4.71	120	1.5	38	6	152	7	177	.644
1"	4.74	120	1.5	38	6	152	7	177	.638

How to specify

Model	Description	Color
17-432	80-mesh disc set	Yellow
17-433	120-mesh disc set	Red
17-434	150-mesh disc set	Black
P30-XXXX	3/4" MNPT w/ disc elements and flush cap	
P31-XXXX	1" MNPT w/ disc elements and flush cap	

XXX = Filter mesh

example:
P30-XXXD 080-80 mesh
 120-120 mesh
 150-150 mesh

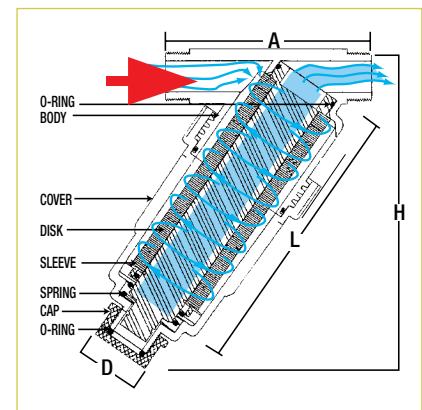

Surface area & flow rate

Size	Filtration surface area		Maximum recommended flow rates		
	in	mm	sq. in	cm ²	GPM
3/4"	20	27.9	180	13	3
1"	25	27.9	180	18	5

1½" & 2" Plastic Filters with Disc Elements

1½" & 2" Plastic Filters with Disc Elements

Features

- Sediments accumulate on the outer face of the stacked discs, allowing clean water to flow through the discs and out the middle of the filter
- Disc elements provide in-depth filtration to retain organic matter
- During operation, the disc elements are tightly pressed together by pressure and the spring, providing high filtration efficiency
- Discs have excellent resistance to most common chemicals
- Easy maintenance – the discs can be extracted for cleaning
- Interchangeable color-coded discs and stainless-steel screen elements provide a wide range of filtration degrees and options
- Constructed of UV-resistant, durable plastic material to withstand the most adverse conditions

Specifications

- Operating pressure: up to 120 PSI (8.4 BAR)
- Flow rates: 1 1/2" & 2": up to 60 GPM (13.6 m³/h)
- Inlet and outlet size: 1 1/2", 2" MNPT
- Temperature range: up to 130°F (54°C)

Filter and Disc Materials

- Housing and discs: polypropylene
- O-ring: EPDM
- Pressure-testing ports: polypropylene
- Pressure-testing seals: natural rubber BR
- Disc cylinder assembly: polypropylene / PBT
- Spring: stainless steel 304

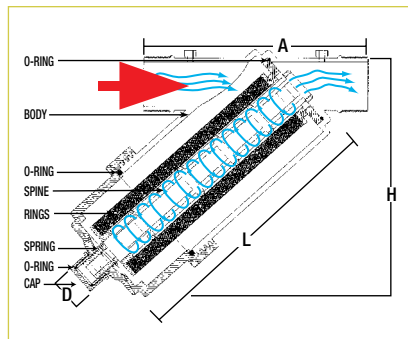

Filter Cover Tool

- Used to open and remove the 1 1/2" and 2" cover



How to specify		
Model	Description	Color
17-040D	40 mesh • 1 1/2" disc set	Blue
17-041D	80 mesh • 1 1/2" disc set	Yellow
17-042D	120 mesh • 1 1/2" disc set	Red
17-043D	150 mesh • 1 1/2" disc set	Black
17-044D	40 mesh • 2" disc set	Blue
17-045D	80 mesh • 2" disc set	yellow
17-046D	120 mesh • 2" disc set	Red
17-047D	150 mesh • 2" disc set	Black
P75-XXXDLI	1 1/2" (long) MNPT disc filter	
P80-XXXD	2" MNPT disc filter	
17-034	filter cover tool	

XXX = Filter mesh

example:
 P80-XXXD 080-80 mesh
 P80-120D 120-120 mesh
 P80-150D 150-150 mesh

Dimension & weight

Size	A		B		C		D		WT
	in	mm	in	mm	in	mm	in	mm	lbs
1 1/2"	10.1	257	3.1	80	8.6	220	9.4	240	2.3
2"	10.1	257	3.1	80	10.4	265	10.6	270	2.6

Surface area & flow rate

Size	Filtration surface area		Maximum recommended flow rates		
	in	mm	sq in	cm ²	GPM
1 1/2"	38	59.7	385	60	15
2"	50	75.6	488	80	20

Filtration degree & material

Mesh	Micron	Material	Color
40	400	Polypropylene	Blue
80	180	Polypropylene	Yellow
120	130	Polypropylene	Red
150	100	Polypropylene	Black

Head loss (PSI)

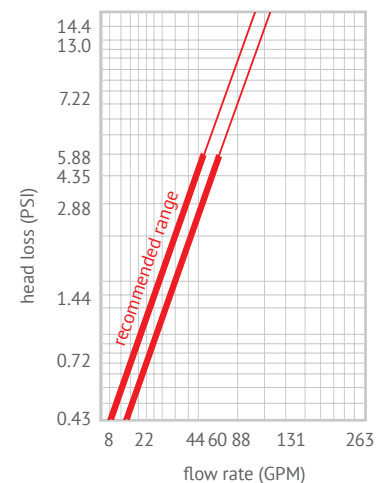



DIG offers both compression and barb fittings to ensure a secure and reliable connection.

DIG's compression fittings are made of high-impact material to ensure a positive connection and a long life. Utilizing spin-weld technology, the ABS bodies are assembled with a polycarbonate insert that is welded into place.

In addition to compression fittings, DIG also provides a universal nut-lock™ fitting line and a complete line of 16 and 17 mm insert fittings to be used with dripline or distribution tubing.

The barbed fittings are designed for easy installation and secure connection without glue or clamps. DIG accessories include a full line of 1/4" connectors, 1/4" inline shut-off valves, 1/4" and 1/2" stakes, shrub adapters, punches, goof plugs and PVC-to-poly inserts.

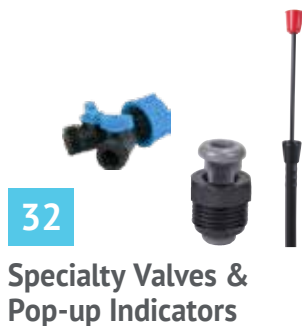

32
Specialty Valves &
Pop-up Indicators



33
Compression &
Universal Fittings

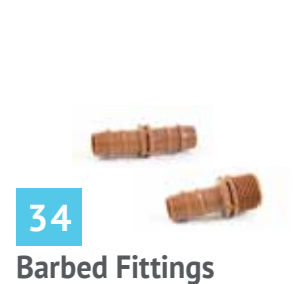

34
Barbed Fittings



35
Shrub Adapters



35
Punches



35
PVC Inserts



35
Threaded Fittings



36
Stakes



32
PE Risers

Shut-Off Valves

Features

- Watertight seal with inlet/outlet O-rings
- Large handle for easy manual control
- Rapid 1/4" turn-on and off
- Constructed of UV-resistant, durable plastic material

Specifications

- Operating pressure: up to 60 PSI (4.1 BAR)
- Temperature range: up to 130°F (54°C)
- Recommended operating pressure: 15 to 30 PSI (1 to 2.1 BAR)
- Materials: high-impact plastic



How to specify

Model	Description
28-004	3/4" FPT x 3/4" MPT (BSP)
28-007	.600" ID barb (17 mm)
28-012	3/4" FPT X .520" ID barb (16 mm)
28-013	520" ID barb (16 mm)
28-015	3/4" .820" ID barb (20 mm)
28-018	3/4" FHT x MHT filter flush valve
36-072	3/4" FHT x two-outlet shut-off valve

Air Relief Valve

Features

- Prevents suction of dirt into the drip laterals via the drippers by preventing vacuum formation
- Large air passage
- Smooth operation
- Constructed of UV-resistant, durable plastic material to withstand the most adverse conditions

Specifications

- Operating pressure: up to 140 PSI (9.8 BAR)
- Temperature range: up to 130°F (54°C)
- Inlet size: 1/2" MNPT
- Plastic with Buna-N seal



How to specify

Model	Description
18-028	1/2" Air vacuum relief valve
DARV-2	1/2" Air vacuum relief valve - Pack of 2

Pop-Up Indicators

Features

- Available in four configurations
- Large red indicator for visibility
- Unique design ensures reliable operation
- Can be installed with EXCEL™ dripline, poly tubing, PVC or used with any drip irrigation system
- Ideal for sub-surface systems and densely planted sites



Specifications

- Operating pressure: 15-35 PSI (1-2.4 BAR)
- Pop-up indicator height:
 - 8" (20 cm) retracted to 13" (33 cm) extended
 - 12" (30 cm) retracted to 21" (53 cm) extended



How to specify

Model	Description
DSPI-08	8" with 1/2" MPT
DSPI-08B	8" with 24" micro tubing and barb
DSPI-12	12" with 1/2" MPT
DSPI-12B	12" with 24" micro tubing and barb

Compression Fittings & Universal Fittings

Compression Fittings

Features

- High-impact plastic
- Color coded
- UV resistant
- Secure and easy installation without glue or clamps
- Fits all DIG 16 mm and 17 mm dripline and polyethylene tubing with .450", .620", .700" and .710" OD

Specifications

- Operating pressure: up to 60 PSI (4.1BAR)
- Materials:
 - Body: ABS
 - Inserts: polycarbonate

How to specify	
Model	Description
Swivel adapter with screen	
24-016	.450" OD x 3/4" FPT
24-001	.630" OD x 3/4" FPT
15-005	.700" OD x 3/4" FPT
15-017	.710" OD x 3/4" FPT
24-028	.630" OD x 3/4" FNPT
24-029	.700" OD x 3/4" FNPT
24-030	.710" OD x 3/4" FNPT

How to specify	
Model	Description
Swivel adapter with washer	
24-017	.450" OD x 3/4" FPT
24-010	.630" OD x 3/4" FPT
15-020	.700" OD x 3/4" FPT
15-021	.710" OD x 3/4" FPT
24-006	.630" OD x 3/4" FNPT
15-024	.700" OD x 3/4" FNPT
15-023	.710" OD x 3/4" FNPT
End cap	
24-018	.450" OD x 3/4" FPT
24-005	.630" OD x 3/4" FPT
15-012	.700" OD x 3/4" FPT
15-018	.710" OD x 3/4" FPT
Adapter	
24-033	.630" OD x 1/2" MPT
24-034	.700" x OD 1/2" MPT
24-035	.710" OD x 1/2" MPT
24-024	.450" OD x 3/4" MPT
24-025	.630" OD x 3/4" MPT
24-026	.700" OD x 3/4" MPT
24-027	.710" OD x 3/4" MPT
24-020	.450" OD x 3/4" MHT
24-021	.630" OD x 3/4" MHT
24-022	.700" OD x 3/4" MHT
24-023	.710" OD x 3/4" MHT
Swivel tee with screen	
24-007	.630" OD x 3/4" FPT
15-008	.700" OD x 3/4" FPT
15-022	.710" OD x 3/4" FPT
PVC-to-Poly Adapter	
24-100	.700" OD x 1/2" PVC Slip

How to specify	
Model	Description
Swivel tee with a washer	
24-058	.630" OD x 3/4" FPT
24-059	.700" OD x 3/4" FPT
24-060	.710" OD x 3/4" FPT
24-064	.630" OD x 3/4" FNPT
24-065	.700" OD x 3/4" FNPT
24-066	.710" OD x 3/4" FNPT
Tee	
24-061	.630" OD x 3/4" MHT
24-062	.700" OD x 3/4" MHT
24-063	.710" OD x 3/4" MHT
Coupling	
24-012	.450" OD
24-002	.630" OD
15-004	.700" OD
15-014	.710" OD
Reducing coupling	
15-003	.700" OD x .710" OD
15-009	.700" OD x .630" OD
15-010	.700" OD x .450" OD
Tee	
24-015	.450" OD
24-003	.630" OD
15-006	.700" OD
15-016	.710" OD
Reducing tee	
24-014	.700" OD x .700" OD x .450" OD
Elbow	
24-013	.450" OD
24-004	.630" OD
15-007	.700" OD
15-015	.710" OD

Universal Fittings

Features

- Fits .620", .700" and .710" OD tubing (16 mm and 17 mm)
- Three-part construction
- Threaded nut for easy assembly
- UV resistant
- Available in four different configurations

Specifications

- Operating pressure: 60 PSI (4.1 BAR)
- Materials:
 - Body and nut: polypropylene
 - Barb: PPT



How to specify	
Model	Description
15-055	Coupling
15-056	Elbow
15-057	Tee
15-058	FPT swivel tee with washer

1/2" Barbed Fittings (17 mm)

Features

- High-impact plastic
- UV resistant
- Secure and easy installation without glue or clamps
- Fits all 1/2" (17 mm) DIG dripline and polyethylene tubing (.570" ID)
- Available with a combination of threads and barbs
- One-piece construction

Specifications

- Operating pressure: up to 30 PSI (2.1 BAR)
- Material: Acetal



How to specify		
Model	Description	17mm
Insert coupling		
15-040	.570" ID	
Insert tee		
15-041	.570" ID	
Insert elbow		
15-042	.570" ID	
1/2" Male adapter tee X barb		
15-043	.570" ID	
3/4" Male adapter tee X barb		
15-044	.570" ID	
3/4" Female adapter tee X barb		
15-045	.570" ID	

How to specify		
Model	Description	17mm
1/2" Male adapter X barb		
15-046	.570" ID	
3/4" Male adapter X barb		
15-049	.570" ID	
1/2" Elbow Male adapter X barb		
15-047	.570" ID	
PVC single starter connector w/ o ring		
15-048	.570" ID	
Insert barbed cross		
15-061	.570" ID	
3/4" Male adapter X barb 'Y'		
15-063	.570" ID	
Poly barbed connector		
15-065	.570" ID	

1/4" and 1/8" Barbed Fittings

Features

- Secure and easy installation without glue or clamps
- Large inside diameter for maximum flow
- One-piece construction
- UV resistant
- Fits 1/4" and 1/8" (.125"-.190" ID) distribution tubing

Specifications

- Operating pressure: up to 30 PSI (2.1 BAR)
- Material: Acetal

How to specify		
Model	Description	
25-001	1/4" Long barb	
25-002	1/4" Tee	
25-003	1/4" Elbow	
25-004	1/4" Short barb	
25-015	1/8" x 1/4" Barb	



Fittings & Accessories

Mini In-Line Shut-Off Valve

Features

- Adjusts flow from 0-25 GPH (0-95 L/H)
- High-impact plastic
- UV resistant
- For secure and easy installation without glue or clamps
- Fits all 1/4" distribution tubing

Specifications

- Oper. pressure: up to 30 PSI (2.1 BAR)
- Flow rates: 25 GPH (95 L/H)
- Maximum head loss: 6 PSI (.4 BAR)



How to specify

Model	Description
16-007	Shut-off valve with 1/4" barb

Shrub Adapters

Features

- For installing a dripper or spray jet on a 1/2" riser
- Available with 10-32 thread or a barb
- UV resistant

Specifications

- Oper. pressure: up to 30 PSI (2.1 BAR)
- 1/2" FNPT x 10-32 thread
- 1/2" FNPT x 1/4" barb



How to specify

Model	Description
16-034	1/2" FNPT with 10-32 thread
16-058APT	1/2" FNPT with press-fit tee
16-054APB	1/2" FNPT with press-fit barb
16-002	1/2" FNPT x 1/2" MNPT with 1/4" barbed elbow

Hose Ends & Goof Plugs

Hose End Features

- Small and large hose ends for easy insertion
- UV resistant
- Made of polypropylene
- Operating pressure: up to 60 PSI

Goof Plug Features

- Used to plug holes in the main line or to stop flow out of the end of 1/4" distribution tubing



How to specify

Model	Description
16-015	3/4" hose end
16-021	1/2" hose end
16-022	Goof plug • strip of 10

Punches

Features

- Used to puncture holes when installing drippers and micro sprinklers in polyethylene tubing
- Easy-grip handle constructed of durable plastic and non-corrosive materials
- Pro punch and deluxe punch pins can be replaced
- Deluxe punch cuts 1/2" polyethylene tubing and 1/4" distribution tubing with the cutter in the handle



How to specify

Model	Description
16-020	Small punch
16-035	Pro punch with 3-mm pin
16-045	Pro punch with 4-mm pin
16-063	Punch for 17-mm adapter
16-064	PNC-CUT
16-065	Deluxe punch with cutter
16-066	Insertion tool
55-102	2 mm pin

PVC Inserts

Features

- Glues into the slip side of any 1/2" PVC fitting
- UV resistant

Specifications

- Operating pressure: up to 80 PSI (5.5 BAR)



How to specify

Model	Description	Color
Inserts for 1/2" PVC		
24-008	.620" OD	Green
15-067	.670" OD	Brown
15-013	.700" OD	Black
15-019	.710" OD	Blue
Insert for 3/4" PVC		
16-018	.930 OD	Gray

Threaded Fittings

Features

- Hose or pipe thread, male and female

Specifications

- Operating pressure: up to 80 PSI (5.5 BAR)



How to specify

Model	Description
16-003	Swivel adapter 3/4" FHT x MNPT w/washer
16-008	3/4" FNPT coupling
16-010	Nipple 3/4" MHT x MNPT
16-013BK	Cap 3/4" FHT w/washer -black
16-013BR	Cap 3/4" FHT w/washer -brown
16-013BL	Cap 3/4" FHT w/washer -blue
16-014	Cap 3/4" FHT w/washer -grey
18-029	3/4" FNPT x 1/2" FNPT adapter

Stakes

Features

- High-impact plastic
- UV resistant
- Stake with flow adjustment available with 10-32 thread
- Flow rate on stake is adjustable to off
- For secure and easy installation of 1/2" polyethylene and 1/4" distribution tubing



How to specify

Model	Description	Color
Pictured from left to right		
16-027	Labyrinth arrow stake for 1/8" tubing	Black
16-011	Stake for 1/2" poly tubing	Black
16-016	"V" stake	Black
16-017	6" Stake w/barb for 1/8" tubing	Black
16-023	4" Stake	Black
16-025	13" Clip stake	Black
16-032	1/2" Heavy-duty stake	Black
16-062	1/2" Heavy-duty stake	Brown
16-042	1/4" Heavy-duty stake	Black
16-072	1/4" Heavy-duty stake	Brown
16-043	Adjustable stake w/ 10-32 thread	Black
16-056	1/4" x 5" Galvanized steel wire	
16-057	1/2" x 8" Galvanized steel wire	
16-059	8" stake w/ 10-32 thread top outlet & side barb inlet	Black

Semi Rigid PE Riser Assemblies on Stake

Features

- Pre-assembled with rigid polyethylene (PE) riser (.160" ID x .300" OD)
- Flow rate on stake is adjustable to off
- Constructed of UV-resistant plastic material



How to specify

Model	Description
PE riser w/ clip spike assembly	
16-048	12"
16-049	16"
PE riser w/adjustable spike assembly	
16-108	8"
16-112	12"
PE riser w/stake assembly	
16-109	8"

Semi Rigid PE Riser & Assemblies

Features

- Pre-assembled with rigid polyethylene (PE) riser (.160" ID x .300" OD)
- Constructed of UV-resistant plastic material



How to specify

Model	Description
PE riser	
12-020	8" PE riser .160"ID x .300"OD
12-022	12" PE riser .160"ID x .300"OD
12-028	16" PE riser .160"ID x .300"OD
PE riser with 1/4" barb	
16-038	12" PE riser .160"ID x .300"OD
PE riser 1/2" MNPT adapter	
16-208	8" PE riser .160"ID x .300"OD



Drip Zone & Pressure Regulators



DIG's P-series pre-assembled drip zones are available in 3/4" or 1" and supported by an adjustable or preset pressure regulator with pipe or hose thread. All units are made of high-impact, UV-resistant plastic to ensure long life.

Simplified valve manifolds offer a quick installation and easy maintenance and do not require glue or Teflon tape. In addition, we offer a wide range of swivel fittings to allow you to customize your manifold design.



38

3/4" & 1" 24VAC Drip Zone Assemblies



39

Heavy Duty Low-to-Medium-Flow Preset Pressure Regulators



40

Adjustable Pressure Regulators



40

Pressure Regulating Filters

3/4" and 1" 24VAC Drip Zone Assemblies

Features

- Each drip zone is assembled with a slow opening and closing valve for better reliability of the system
- Large filter screen provides greater filtration and operation efficiency
- Designed with ease of maintenance for small-sized enclosures
- Constructed of UV-resistant, durable plastic material to withstand the most adverse conditions
- Filtration area: 11 in² (71 cm²)
- Temperature range: up to 130°F (54°C)
- 3/4" FNPT x MNPT or FNTP

Materials

- Body: durable plastic
- Spring: stainless steel 304

Specifications

- Operating pressure: 10-120 PSI (.7-8.3 BAR)
- Flow rates: .1-12 GPM (.23-3.6 m³/h)
- Pressure range sets:
 - P39-075: 12-35 PSI (.8-2.4 BAR)
 - P40-075: 30 PSI (2.1 BAR)
 - P55-100: 30 PSI (2.1 BAR)

Dimensions

- 1.3" L x 9" H (3.2 cm L x 22.3 cm H)



How to specify

Model	Description
P39-075	3/4" drip zone with 24VAC, 155-mesh filter and adjustable pressure regulator
P40-075	3/4" 24VAC valve assembly FNPT x MNPT with 155-mesh, 3/4" filter and 3/4" preset pressure regulator (30 PSI)
P55-100	1" 24VAC valve assembly FNPT x FNTP with 155-mesh, 1" filter and 1" preset pressure regulator (30 PSI)

Pressure Regulators

Heavy Duty – Low-to-Medium-Flow Preset Pressure Regulators

Features

- Available with 3/4" FPT or FHT inlet
- Exceptional control of outlet pressure
- Withstands severe water hammer
- Utilizes a minimum of moving parts and a diaphragm design that regulates itself in reaction to overall system back pressure.
- Engineered with extra thick industrial-strength ABS plastic with all joints sonic welded into a tamper proof, impact-resistant housing
- Install above or below grade and in downstream pressure

Specifications

- FNPT pressure range: 20, 25, 30, 35 & 40 PSI
- FHT pressure range: 25 PSI
- Operating pressure up to 120 PSI
- Flow rate from .5 to 12 GPM
- Max. recommended flow rate: 12 GPM
- Overall length 4.025"
- Outside diameter 1.845"
- Inlet 3/4" FIPT (standard) or FHT
- Outlet 3/4" FIPT or 3/4" MNPT or MHT
- Materials:
 - Body: chemical resistant ABS plastic
 - Diaphragm: EPDM
 - Spring: stainless steel



How to specify

Model	Description
18-020	20 PSI • 3/4" FNPT x 3/4" MNPT
18-025	25 PSI • 3/4" FNPT x 3/4" MNPT
18-030	30 PSI • 3/4" FNPT x 3/4" MNPT
18-325	25 PSI • 3/4" FNPT
18-330	30 PSI • 3/4" FNPT
18-335	35 PSI • 3/4" FNPT
18-340	40 PSI • 3/4" FNPT
18-130	30 PSI • 3/4" FHT x MHT

Flow rate vs. pressure 18-020

Flow (GPM)	Input pressure (PSI)			
	40	50	60	80
0.5	20.0	20.0	20.0	20.0
1.0	19.8	19.8	19.8	19.8
3.0	19.8	19.8	19.8	19.8
6.0	19.7	19.7	19.6	19.6
9.0	19.3	20.0	20.0	20.0
12.0	17.7	19.2	20.0	20.0

Flow rate vs. pressure 18-025

Flow (GPM)	Input pressure (PSI)			
	30	40	50	60
0.5	24.7	25.9	26.0	26.1
1.0	24.3	24.4	24.6	25.5
3.0	24.2	24.2	24.1	24.1
6.0	23.9	24.0	23.9	23.8
9.0	22.8	24.4	24.3	24.1
12.0	21.8	24.4	24.8	24.7

Flow rate vs. pressure 18-325

Flow (GPM)	Input pressure (PSI)			
	40	50	60	80
0.5	23.5	23.7	24.0	24.4
1.0	23.3	23.5	23.6	23.7
3.0	23.7	23.7	23.7	23.7
6.0	23.5	23.5	23.5	23.5
9.0	21.9	23.5	23.6	23.7
12.0	19.7	21.3	24.0	24.5

Flow rate vs. pressure 18-130 & 18-330

Flow (GPM)	Input pressure (PSI)			
	40	50	60	80
0.5	29.2	29.5	29.9	31.0
1.0	29.0	29.5	29.5	30.0
3.0	29.5	29.3	29.6	29.6
6.0	28.0	28.5	29.0	29.3
9.0	24.0	27.0	29.0	29.5
12.0	22.0	24.8	29.0	30.0

Flow rate vs. pressure 18-335

Flow (GPM)	Input pressure (PSI)			
	40	50	60	80
0.5	35.0	35.0	35.0	35.2
1.0	34.4	34.6	34.6	34.8
3.0	34.0	34.6	34.6	34.6
6.0	30.3	34.2	34.3	34.3
9.0	28.9	32.0	34.0	34.3
12.0	22.9	29.0	32.0	35.5

Flow rate vs. pressure 18-340

Flow (GPM)	Input pressure (PSI)			
	40	50	60	80
0.5	39.0	40.0	40.5	41.0
1.0	39.0	40.0	40.0	40.0
3.0	37.0	40.0	40.0	40.0
6.0	32.0	37.0	39.0	40.0
9.0	29.0	36.0	39.0	40.0
12.0	24.0	30.0	36.0	41.0

Adjustable Pressure Regulators

Features

- Adjustable with a single screw
- Rolling diaphragm keeps the spring assembly free of debris
- Reliable control regardless of fluctuations in upstream pressure or flow

- Rolling diaphragm: nylon reinforced neoprene
- Spring: stainless steel 304

Dimensions

- 4" H x 3.4" W (10.2 cm H x 8.6 cm W)



Specifications

- Pressure range: 12-60 PSI (.8-4.1 BAR)
- Max. working pressure: 125 PSI (8.6 BAR)
- Flow rates: .2-22 GPM (.045-5 m³/h)
- Weight: .75 lb (.34 kg)
- 3/4" FNPT

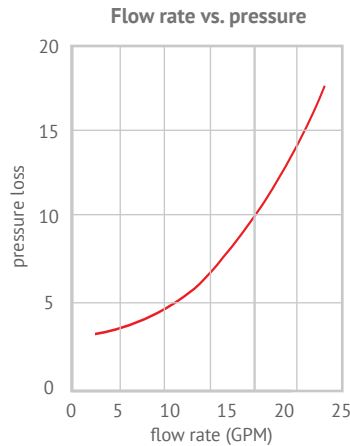

How to specify

Model	Description
18-008	12-35 PSI
18-007	28-60 PSI

Materials

- Body and actuator: plastic

Pressure Regulating Filters

Features

- Combination unit helps make installation easier and faster
- Heavy duty glass-filled polypropylene body
- Works with all valves
- Comes with 155-mesh screen pre-assembled (replacement filter elements are available)

- 25 PSI or 45 PSI pressure regulator is integrated into the filter body.

Specifications

- Operating pressure: up to 120 PSI
- Preset pressure rating: 25 PSI or 45 PSI
- Screen: stainless steel 155 mesh/100 micron
- Body: glass-filled polypropylene

Dimensions

- 6" L x 4 1/4" H x 1 3/4" W



Flow rate with pressure loss 3/4" pressure regulating filter

Flow (GPM)	PRF-25-075 (PSI)	PRF-45-075 (PSI)
0.2	1	6
1	3	2
3	3	6
5	6	9
*8	8	14
*10	9	26
*15	N/A	N/A

*Not recommended

Flow rate with pressure loss 1" pressure regulating filter

Flow (GPM)	PRF-25-100 (PSI)	PRF-45-100 (PSI)
0.2	1	1
1	4	2
3	5	8
5	10	14
*8	N/A	18
*10	N/A	N/A
*15	N/A	N/A

*Not recommended

How to specify

Model	Description
PRF-25-075	3/4" pressure regulating filter
PRF-25-100	1" pressure regulating filter
PRF-45-075	3/4" pressure regulating filter
PRF-45-100	1" pressure regulating filter
17-056	filter only

Battery Powered Controllers and Timers



Automating irrigation systems does not have to be a difficult, time consuming job. DIG's extensive line of battery operated controllers and DC hose end timers are all designed to be easy to install and program, delivering years of reliable automatic operation, even in the harshest environments.



42

410BT Bluetooth® Battery Powered Controller



43

400A-Series Battery Powered Controller



44

710A-Series Battery Powered Controller



45

7X0A-Series, Two-, Four- and Six-Station Battery Powered Controllers



46

710AP-Series Battery Powered Controller



47

BOHE-BT Hose End Battery Powered Timer



48

Hose End Battery Powered Timers

410BT Bluetooth® Battery Powered Controller

Features

- Simple to program
- Easy to set up, install and operate
- Available in many languages
- Bluetooth communication range: up to 50' (15 m)
- Manual irrigation cycle can be performed in three different ways: using the app, using the timer's manual program button or using the solenoid
- Environmentally friendly; utilizes RoHS compliant components
- Completely waterproof (IP68) - can operate in harsh environments
- Battery life of up to one year



Programming

- Program runtime from 1 minute up to 12 hours in 1-minute increments
- Custom program-scheduling using a weekly calendar, odd days, even days or intervals of 1-30 days utilizing a yearly calendar with leap year
- Five start times per day
- Budgeting by month up to 200% in 5% increments
- Rain delay option of up to 99 days with automatic restart for water conservation
- Up to nine scheduled off dates per year (preventing the controller from operating on those specific days)
- Up to 12 months of irrigation runtime history information available on app
- Instantaneous communication with your smartphone or tablet once connected
- Password protection capabilities
- One button to reset the controller to factory defaults or to run manually without a smart device
- Remaining battery life, connection strength, controller's current watering status and last watering information are easily displayed from the app

Specifications

- Operating pressure: 10 to 150 PSI (.7 to 10.3 BAR)
- Flow range: .1 to 28 GPM (.4 to 106 L/M)
- Temperature range: 38-130°F (3-54°C)
- Inlet and outlet: female pipe thread (FNPT) or British standard thread (BSP)
- Includes one each of 3/4" FHT x MHT and MPT x MHT adapters with FNPT configuration only
- Power source: two AA alkaline batteries (not included)
- Solenoid with enclosed plunger: two-way magnetic latching, normally closed, 7-12 Volt DC with two wires
- Solenoid wire: 12"
- Valve: 3/4" FNPT heavy-duty globe valve with flow control
- Materials:
 - Timer housing: high-impact plastic
 - Inline valve and solenoid: glass-reinforced nylon

How to specify

Model	Description
410BT Controller only	
410BT-000	Controller with 3 adapters
410BT with Anti-Siphon Valve or Actuator	
410BT-ASV	3/4"
410BT-MVA	3/4"
410BT with Inline Valve	
410BT-075	3/4"
410BT-100	1"
410BT-150	1 1/2"
410BT-200	2"
410BT Inline Valve with BSP thread	
410BT-075BSP	3/4"
410BT-100BSP	1"
410BT-150BSP	1 1/2"



400A Series | Single-Station Battery Powered Controller

400A Series | Single-Station Battery Powered Controller

Features

- Simple to program
- Multiple programming options
- Large LCD screen and easy-to-read icons
- Rain sensor compatible
- Available with an in-line valve, anti-siphon valve, actuator or solenoid with three adapters
- Sealed potting design provides IP68-rated waterproofing
- Durable construction whether below grade in a valve box or above grade
- Battery life of up to three years
- Three-year warranty

Programming

- Four start times per day provide added flexibility for any type of watering application including sandy or clay soil
- Valve duration of up to 5 hours and 59 minutes in 1-minute increments
- Custom program-scheduling using a weekly calendar, odd days, even days, or intervals from 1-30 days utilizing a yearly calendar with leap year
- Rain Delay with up to 99 days with auto restart



Specifications

- In-line valve operating pressure: 10 to 150 PSI (.7 to 10.5 BAR)
- Power source: two AA alkaline batteries (not included)
- Available sizes:
 - 1", 1 1/2" and 2" swivel FNPT
 - 3/4", 1", 1 1/2" and 2" MNPT
- Temperature range: up to 130° F (54°C)
- Body and swivel: polypropylene UV
- O-ring: Nitril rubber

How to specify

Model	Description
400A controller only	
400A-000	Controller with three adapters
400A in-line valve	
400A-075	3/4"
400A-100	1"
400A-150	1 1/2"
400A-200	2"
400A inline valve with BSP thread	
400A-075BSP	3/4"
400A-100BSP	1"
400A-150BSP	1 1/2"
400A-200BSP	2"

Available solenoid valve adapters

Model	Compatible valves
30-920	BERMAD series 200, HIT series 500, DOROT series 80, GRISWOLD series 2000, DW and BUCKNER series VB valves
30-921*	RAIN BIRD DV, DVF, PGA, PEB (1" only), GB, EFB-CP, BPE, PESB (1" only) and ASVF valves
30-922*	HUNTER series ASV, HPV, ICV, PGV, SRV, IBV and ASVF valves
30-923	WEATHERMATIC series 12000, 21000 and 8200CR valves
30-924*	IRRITROL series 100, 200B, 205, 217B, 700, 2400, 2500 and 2600, TORO series 220 and P220 valves
30-925	SUPERIOR series 950, HUNTER HBV and TORO series 252 valves (1.5" and larger)
30-926	RAIN BIRD SERIES PEB and PESB (1 1/2" and 2" ONLY) valves

*Included with model 400A-000



710A Series | Single-Station Battery Powered Controller

Features

- Single-station battery operated controller available with an inline valve, anti-siphon valve, actuator or solenoid with three adapters
- Seven-button keypad with an integrated LCD display
- Easy to read AM/PM clock
- Automatic, semi-automatic and manual operation
- Withstands harsh climatic conditions
- Mounting configurations include a valve clip and box wall mounting
- On activation, the controller display indicates when a program is running and when any programming feature is active
- Program On/Off button: allows the user to turn off the controller and reactivate it as desired
- Non-volatile memory
- Rain sensor connection
- Daily and monthly programming complies with city and municipal watering restrictions
- Three-year warranty

Programming

- Watering durations in 1-minute increments from 1 minute to 5 hours and 59 minutes
- Five start times per day provide added flexibility for any type of watering application including sandy or clay soil
- Custom program-scheduling using a weekly calendar, odd days, even days, or intervals from 1-30 days utilizing a yearly calendar with leap year
- Monthly water budgeting from 0%-200% in 5% increments
- Rain delay option with automatic restart up to 99 day
- Twenty preset programs of historical evapotranspiration (ET) for spray heads and drip irrigation with editing feature



Specifications

- In-line valve operating pressure: 10 to 150 PSI (.7 to 10.5 BAR)
- Power source: two AA alkaline batteries (not included)
- Battery life: up to three years
- Temperature range: 38°F to 130°F (3°C to 54°C)
- Solenoid: two-way magnetic latching, bi-directional pulse (included)

Controller & Valve Dimensions

- Controller only: 4.2" H x 5" L x 3.6" W
- Controller with 3/4" or 1" valves: 8" H x 5" L x 3.6" W (20.3 cm H x 12.7 cm L x 9.1 cm W)
- Controller with 1 1/2" or 2" valves: 10.5" H x 8.5" L x 5" W (26.7 cm H x 21.6 cm L x 12.7 cm W)

How to specify

Model	Description
710A-000	Single-station controller with solenoid
710A-011	With actuator
710A-075	With 3/4" in-line valve
710A-100	With 1" in-line valve
710A-150	With 1 1/2" in-line valve
710A-200	With 2" in-line valve
710A-ASV-075	3/4" ASV with 710 battery controller
710A-ASV-100	1" ASV with 710 battery controller



7X0A Series | Two-, Four- and Six-Station Controllers

7X0A Series | Two-, Four- and Six-Station Battery Powered Controllers

Features

- Powered by two AA alkaline batteries with a safe period of 60 seconds
- Operates up to six stations, a master valve and a sensor
- Icon-based intuitive programming and EasyFlow™ navigation
- SimpleSmart™ historical ET feature that automatically adjusts irrigation schedules monthly
- Can operate any number of valves
- Low battery indicator
- Upon insertion of the batteries, the controller follows a start-up sequence to test that each solenoid is closed
- Rain delay for up to 99 days
- Daily and monthly programming restriction options to comply with city and municipal watering restrictions
- Display turns off automatically to conserve energy
- Semi-automatic and manual operation by valve or by program
- Easy On/Off button
- Brackets for solenoid and wall mounting are included
- Utilizes RoHS compliant components
- Solenoid wires can be extended up to 100' (18 AWG)
- Reset option to return controller to default settings excluding time and date
- Non-volatile memory holds all programs indefinitely without batteries
- Completely waterproof (IP68)
- Easily retrofits to most manufacturers' valves with DIG's S-305DC solenoid and one of DIG's seven adapters
- Three-year warranty

Programming

- Four programs with five start times per day
- Custom program-scheduling using a weekly calendar, odd days, even days, or intervals from 1-30 days utilizing a yearly calendar with leap year
- Durations of up to 5 hours and 59 minutes in 1-minute increments
- Twenty preset historical ET programs available for 10 climate zones, with 10 for drip irrigation and 10 for spray heads. Can be used with any irrigation setup and includes the option to review the new calculated duration
- Monthly seasonal adjustment that modifies the duration from 5% to 200% in 5% increments. Also can be used to fine-tune the preset ET program for each month
- On/Off button allows the user to turn off the controller system or an individual program and reactivate it as desired

Specifications

- Type: DC
- Body: IP68
- Power source: two AA alkaline batteries (not included)
- Power input per valve: constant 11 volt
- Wire configurations: up to six 18" red wires labeled for each valve, one black wire for master valve, two white wires



How to specify

Model	Description
720A	720A • Two stations
740A	740A • Four stations
760A	760A • Six stations

for common and one looped yellow wire for sensor connections

- Temperature range: 38°F to +130°F (3°C to +54°C)
- Sensor connection: normally closed 6" (15 cm) looped yellow wire (16 AWG)
- Materials: high-impact plastic
- Used with S-305DC 7-12 VDC normally closed, two-way latching solenoid and 30-92X adapters (page 63)



710AP Series | Battery Powered Propagation Controller

710AP Series Battery Powered Propagation Controller

Features

- Powered by two AA alkaline batteries
- Three-year battery life
- Up to five start times per day
- Low battery indicator
- Display indicates if irrigation is set to water for the day and if any of the additional programming features are active
- Simple, icon-based intuitive programming and EasyFlow™ navigation
- After 15 minutes, the controller screen turns off automatically to conserve energy
- Semi-automatic and manual operation with timed countdown for shutoff
- System On/Off button allows the user to turn off the controller's programming and reactivate it as desired
- Utilizes RoHS compliant
- Non-volatile memory holds programs indefinitely, except date and time
- Completely waterproof (IP68)
- Rain sensor connection included
- Easily retrofits to most manufacturers' valves with one of DIG's seven adapters (see page 63)
- Three-year warranty

Specifications

- Seven keypad buttons with integrated liquid crystal display
- Temperature range: 38°F to +130°F (3°C to +54°C)
- Solenoid: 7-18 VDC, two-way latching, normally closed
- Solenoid control orifice: .065" (1.65 mm)
- Encapsulated solenoid thread: 11/16"-12 UN male thread
- Retractable solenoid wire: 4.1" (coiled length when extended, approximately 18")
- Sensor connection: normally closed 6" (15 cm) AWM 1007 / 1569 16 AWG 300V VW-1-yellow wire
- Mounting options: solenoid and wall bracket included

Programming

- Custom program-scheduling using a weekly calendar, odd days, even days, intervals from 1-30 days utilizing a yearly calendar with leap year, or 1 to 12 hours and 1 to 59 minutes.
- Five start times per day in normal mode and one start and stop time per day with watering intervals of every 1 minute up to 12 hours in propagation mode.
- Durations of up to 5 hours and 59 minutes in 1-minute increments in normal mode or from 5 seconds to 59 minutes in 1-second increments in propagation mode.
- Monthly seasonal adjustment with the option to reduce the program duration setting to 5% of normal or to increase it up to 200% in 5% increments without modifying the controller's program duration in irrigation schedules
- Irrigation suspension for up to 99 days with auto restart; resumes irrigation automatically



How to specify

Model	Description
710AP-000	Including adapters for DIG, Rain Bird, Hunter and Toro valves
710AP-075	3/4" FNPT inline valve
710AP-100	1" FNPT inline valve
710AP-075BSP	3/4" inline valve
710AP-100BSP	1" BSP inline valve

- Program Off button allows the user to turn off the controller and reactivate it as desired as well as to quickly activate or deactivate propagation programs.
- Manual On/Off button with a semi-automatic feature opens the valve and utilizes the program runtime to display the time left in the run; it can be pressed again to quickly shut off the valve.



BOHE-BT Bluetooth® Hose End Timer

BOHE-BT Bluetooth® Hose End Timer

Features

- Operating pressure: 10 to 120 PSI (.7 to 8.3 BAR)
- Flow range: .1 to 6 GPM (.38 to 22.71 L/M)
- Temperature range: 38-130°F (3-54°C)
- Inlet and outlet: female hose thread (FHT) x male hose thread (MHT) or British standard thread (BSP)
- Power source: two AA alkaline batteries (not included)
- Solenoid: two-way magnetic latching, normally closed, 7-12 Volt DC
- Materials:
 - Timer housing: high-impact plastic
 - Inline valve and solenoid: glass-reinforced nylon

Programming

- Program runtime from 1 minute up to 12 hours in 1-minute increments
- Custom program-scheduling using a weekly calendar, odd days, even days or intervals of 1-30 days utilizing a yearly calendar with leap year
- Five start times per day
- Budgeting by month up to 200% in 5% increments
- Rain delay option of up to 99 days with automatic restart for water conservation
- Up to nine scheduled off dates per year (preventing the controller from operating on those specific days)
- Up to 12 months of irrigation runtime history information available on app
- Instantaneous communication with your smartphone or tablet once connected
- Password protection capabilities
- One button on the timer to reset the controller to factory defaults or to run manually without a smart device
- Remaining battery life, connection strength, controller's current watering status and last watering information are easily displayed from the app
- Previous connection information of all timers viewable on app if you have more than one



How to specify

Model	Description
BOHE-BT	Bluetooth® hose end timer
BOHE-BTi	Bluetooth® hose end timer w/ BSP thread



B092A Two-Dial Hose End Timer

Features

- Two-dial, single-button programming
- Manual irrigation cycle via the controller
- Powered by one 9-volt alkaline battery
- Battery life: up to one year
- LED battery status indicator
- Irrigation suspension override (rain mode)
- 3/4" FHT inlet and MHT outlet

Programming

- Watering frequencies from once every six hours to once every seven days
- Ten preset durations from two minutes to four hours
- Duration can be changed after programming by setting the selector to a different setting

- Up to four start times per day
- Program start time may be delayed in advance by any number of hours

Specifications

- Operating pressure: 15-80 PSI (1-5.5 BAR)
- Flow rate: up to 5.2 GPM at 30 PSI (19.7 L/H at 2.1 BAR)
- Temperature range: 38°F to 130°F (3°C to 54°C)
- Solenoid mechanism: durable electric motor
- Power source: 9-volt DC (one 9-volt alkaline battery, not included)
- Materials:
 - Body: ABS
 - Inner parts: acetal

Dimensions

- 6" W x 4" D x 6.5" H (15.2 cm W x 10.1 cm D x 16.5 cm H)



How to specify

Model	Description
B09D	3/4" hose end timer with LCD display
B092A	3/4" hose end timer with two dials

B09D Digital Hose End Timer

Features

- Six buttons with a large liquid crystal display
- Manual irrigation cycle via the controller
- Powered by one 9-volt alkaline battery
- Battery life: up to one year
- Low battery indicator
- Irrigation suspension override (rain mode)
- 3/4" FHT inlet and MHT outlet

Programming

- Easy-to-read AM/PM clock
- Simple icon-based programming
- Watering durations from 1 minute to 12 hours and 59 minutes in 1-minute increments
- Seven-day calendar schedule
- Four start times per day
- Emergency backup program of

5 minutes every 24 hours if no buttons are pressed after the battery installation

Specifications

- Operating pressure: 15-80 PSI (1-5.5 BAR)
- Flow rate: up to 5.2 GPM at 30 PSI (19.7 L/H at 2.1 BAR)
- Temperature range: 38°F to 130°F (3°C to 54°C)
- Solenoid mechanism: durable electric motor
- Power source: 9-volt DC (one 9-volt alkaline battery, not included)
- Materials:
 - Body: ABS
 - Inner parts: acetal

Dimensions

- 6" W x 4" D x 6.5" H (15.2 cm W x 10.1 cm D x 16.5 cm H)



How to specify

Model	Description
B09D	3/4" hose end timer with LCD display
B092A	3/4" hose end timer with two dials

Ambient Light (Solar) Powered Timers & Controllers



DIG has developed a fully self-sustainable line of irrigation timers and controllers that are powered entirely by ambient light (solar). DIG's LEIT[®] system requires no direct sunlight and can obtain enough power from ambient light to operate both day and night in any weather condition.

The LEIT-2ET system is programmed to monitor, control and adjust irrigation schedules for each zone through evapotranspiration (ET_o) data transmitted hourly and daily during daytime from a local weather station and site information received from the LEIT RC2ET handset.



50

EVO 100 Hose End Timer



51

LEIT 2 ET Controller



53

LEIT 2 ET Accessories



54

LEIT 1 Controller



55

LEIT 4000



57

LEIT X & XRC



59

LEIT Accessories

EVO 100 | Solar Powered Hose End Timer

DIG's EVO 100 is the most innovative in DIG's new generation of premium automatic controllers and timers. Completely waterproof, the EVO 100 is a DC timer with a built-in solenoid and high-flow diaphragm valve for reliable operation in all conditions.

Features

- Powered by a patented, time-tested internal photovoltaic module and microelectronic energy management system fueled by ambient light (solar)
- Watering flexibility with a selection of watering frequencies and four start times per day
- Manual irrigation cycle can be performed via the manual program button
- Energy conservation feature automatically turns the screen off after 15 minutes
- Easy rain-sensor installation
- Waterproof construction
- Environmentally friendly and energy independent
- Three-year warranty
- Ideal for drip or sprinkler systems
- No batteries needed
- Attaches to any faucet for automatic watering

Programming

- Custom program-scheduling using a weekly calendar, odd days, even days, or intervals from 1-30 days utilizing a yearly calendar with leap year
- Four start times per day
- Durations of up to 5 hours and 59 minutes in 1-minute increments
- Irrigation suspension for up to 99 days with auto restart; resumes irrigation automatically
- Program Off button allows the user to turn off the controller and reactivate it as desired
- Manual On/Off button with a semi-automatic feature that utilizes the program runtime with the option to quick override

Specifications

- Operating pressure: 10 to 100 PSI (.7 to 6.9 bar)
- Flow range: .1 to 8 GPM (.38 to 30 L/H)
- Temperature range: 38-130°F (3-54°C)
- Connection: female hose thread inlet (FHT) x male hose thread outlet (MHT) or British standard thread for tap (BSP)
- Power source: ambient light (solar)
- Sensor connection: yellow wire for closed contact rain sensor
- Input: 3,000 - 100,000+ LUX
- Seven keypad buttons with an integrated liquid crystal display
- Sensor connection: yellow wire for closed contact sensor
- Controller dimensions: 5.8" W x 6.8" H x 2.3" D (14.7 cm W x 17.3 cm H x 5.8 cm D)
- Unit Weight including plastic clam-shell packaging: 1.03 pounds (.47 kg)
- Materials:
 - Timer housing: high-impact plastic
 - Inlet valve and solenoid: glass reinforced nylon with a stainless-steel plunger and spring



How to specify

Model	Description
EVO 100	3/4" solar powered hose end timer w/LCD display



Tip: Before programming, the EVO 100 requires 1-2 hours of charging in sunlight. It will stay fully charged with as little as 10 minutes of ambient light per day.

LEIT 2 ET Two-Station Solar Powered Wireless Controller

The LEIT 2 ET can be programmed to monitor, control and adjust irrigation schedules for each zone by using evapotranspiration (ETo) data transmitted hourly and daily during daytime from a local weather station and site information received from the LEIT RC2 ET handset.

Features

- Environmentally friendly, RoHS-compliant components
- Waterproof, IP68 compliance
- PVM and microelectronic management system fueled by ambient light (solar)
- Operates up to two stations and a rain sensor
- Unique Client ID identity code for controller and handset
- If ET is activated, information provided by the handset and information transmitted from the weather station sensors are used to override or adjust daily scheduled irrigation programs
- Utilizes ISM band radio frequency band (915MHz NA, 866.5MHz Hong Kong, 868MHz International) CE, IC, FCC certified, Australia and Hong Kong compliant
- Non-volatile memory retains program and controller integrity
- Program stacking feature prevents hydraulic overload
- Custom station grouping allows the controller to operate the two stations simultaneously if hydraulic limitations are not exceeded
- Available with 18" (45 cm) color-coded 16-gauge wires for each valve and rain sensor
- Three mounting configurations including green, tan and purple valve box mounts; direct-to-valve clip mounting and column mounting with 25" (63 cm) or 50" (127 cm) mounting columns
- Three-year manufacturer's warranty

Specifications

- Power source: ambient light (solar)
- Controller power input: 3,000 – 100,000+ LUX
- Operating temperature: 32°F to 149°F (0°C to 65°C)
- Power input: 11-volt DC pulse
- Body: IP68
- Number of stations: two
- Station capacity: one 7-12 volt DC pulse, two-way latching solenoid (S-305DC) per each set of red and white wires
- Controller wires gauge: 16 AWG
- Wireless transmitter power and frequency: -7 dBm @ 920 MHz / -7 dBm @ 868 MHz / -7 dBm @ 866 MHz
- Rain sensor connection: normally closed
- Dimensions: 3" W x 5.5" L including antenna (7.6 cm W x 14 cm L)



How to specify

Model	Description
LEIT-2ET system controller	
LEIT 2 ET	USA, Canada, Australia & Japan



DIG's weather-based wireless irrigation control system is composed of a wireless handset, a two-station controller, and an ambient light (solar) powered weather station. The LEIT 2 ET system is programmed to monitor, control and adjust irrigation schedules for each zone by using evapotranspiration (ET_o) data transmitted hourly and daily during daytime from a local weather station and site information received from the LEIT RC2 ET handset. The LEIT RC2 ET remote control handset can communicate with up to 99 LEIT 2 ET controllers, or 198 valves from up to 350' (107 m) line of sight.

Features

- Simple, icon-based programming
- Programs the LEIT 2 ET controller, reviews status information, updates ET information, checks history reports, adjusts budgeting, programs rain delays and performs manual runs or tests
- Environmentally friendly - RoHS compliant components

Programming

- Two independent programs with four start times per program
- Scheduled watering times run from 1 minute to 5 hours and 59 minutes
- 365-day calendar with leap year
- Custom program-scheduling using a weekly calendar, odd days, even days, or intervals from one to thirty (1-30) days utilizing a yearly calendar with leap year
- Rain delay of up to 99 days with auto-restart
- Monthly "Off" feature allows it to be inactive any month of the year
- Permanent Event "Off" feature allows for three inactive days per year
- Water budgeting from 10-200% in 10% increments
- Site or zone information input into each valve when ET is active with the ET editing feature
- History Report on valve run times, ET savings in percentage and total time saved
- Manual test and manual run performed via the RC2 ET handset
- Global Stop command turns off all valves with the same Client ID within radio range

- Wind sensor setting can be set to shut down any controller within range if wind speeds exceed 8-25 miles per hour (12.9-40 Km/h)

Specifications

- Remote handset input: 12-volt DC
- Power supply: rechargeable 3.6V Ni/MH
- Communication distance: 350' (107 m) line of site
- Wireless transmitter power and frequency: 7 dBm @ 920 MHz / -7 dBm @ 868 MHz / -7 dBm @ 866 MHz
- Dimensions: 2.25" W x 5.5" L including antenna (5.7 cm W x 14 cm L)



How to specify

Model	Description
LEIT RC2 ET remote control handset	
LEIT RC2 ET	USA, Canada & Japan



LEIT 2 ET Wireless Weather Station & Accessories



Weather Station Features

- Transmitted weather data is stored by the controller(s) and is reviewable by the LEIT RC2 ET handset(s)
- Self-emptying tipping bucket rain gauge reads rainfall in 0.01" (.254 mm) increments
- The LEIT WWS alerts LEIT 2 ET controllers to completely stop irrigation in extreme weather conditions

Weather Station Specifications

- Power source: ambient light (solar)
- Controller power input: 3,000 – 100,000+ LUX
- Operating temperature: 14°F to 130°F (-10°C to 54°C)
- Wireless transmitter power and frequency: -7 dBm @ 920 MHz / -7 dBm @ 868 MHz / -7 dBm @ 866 MHz
- Humidity range and resolution: 1-99% (100% inches Hg)
- Relative humidity accuracy: +/- 2%
- Temperature resolution and accuracy: -40°F to +170°F (-40°C to +77°C) +/- 1%
- Wind speed resolution and accuracy: 0 MPH (KPH) to 30 MPH (49 KPH) +/- 1%
- Rainfall resolution and accuracy: .01" accuracy +/- 2% @ 2" per hour
- Dimensions: 6.07" W x 9.5" H x 13.65" D (15.42 cm W x 24.13 cm H x 34.67 cm D)
- Mounting connection: 1" x 12" mounting column and integrated clamp with two screws
- 350' line of sight handset range

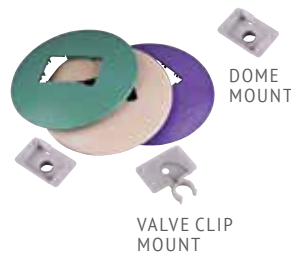

Features

- The LEIT 2 ET has three mounting configurations to fit any application
- Valve clip mounting can attach the controller directly to the S-305DC solenoid
- Valve box mounting with three different colors: green, tan and purple



Features

- Column mounting allows the controller to be above the ground using a 25" or 50" galvanized mounting column



Features

- Easily keeps a full charge out in the field with the convenient car charger
- Nylon carrying case protects the handset

How to specify

Model	Description
For use with LEIT 2 ET controllers only	
30-830	LEIT 2 controller valve box dome attachment with 8 screws (green)
30-831	LEIT 2 controller plastic column attachment
30-832	LEIT 2 controller valve clip attachment
30-835	LEIT 2 controller valve box dome attachment with 8 screws (tan)
30-836	LEIT 2 controller valve box dome attachment with 8 screws (purple)
MCOL2S	LEIT 2 controller 25" (63 cm) mounting column
MCOL2L	LEIT 2 controller 50" (128 cm) mounting column
For use with LEIT 2 ET handsets only	
30-850	LEIT RC2 handset power supply 120 VAC/60 HZ, 12 VDC @ 150 mA
30-851	LEIT RC2 handset car charger - 4' Cable
30-852	LEIT RC2 handset holder

How to specify

Model	Description
LEIT-2ET weather station	
LEIT WWS	USA, Canada, Australia & Japan

LEIT 1 Single-Station Ambient Light (Solar) Powered Controller

The LEIT 1 is a self-sustainable irrigation controller powered by light (solar). The LEIT-1 requires no direct sunlight and can obtain enough power from the surrounding light to operate both day and night in any weather condition.

Features

- Available with an inline valve, anti-siphon valve, actuator or solenoid with three adapters
- No backup battery or AC power necessary – uses clean solar energy
- Simple, icon-based intuitive programming
- Daily and monthly programming complies with city and municipal watering restrictions
- Manual On/Off button opens the valve and shows the time left to run
- Waterproof and humidity resistant
- Power level meter indicates the approximate charge (energy available)
- On activation, the controller display indicates when a program is running and when any programming feature is active
- User reset option allows erasing of all programs to default settings except time, day and date
- Program On/Off button: allows the user to turn off the controller and reactivate it as desired
- Non-volatile memory
- Rain sensor connection
- Three-year warranty

Programming

- Custom program-scheduling using a weekly calendar, odd days, even days, or intervals from 1-30 days utilizing a yearly calendar with leap year
- Five start times per day provide added flexibility for any type of watering application including sandy or clay soil
- Durations of up to 5 hours and 59 minutes in 1-minute increments
- Twenty preset historical ET programs with 10 climate zones, 10 for drip irrigation and 10 for spray systems
- Monthly seasonal adjustment budget (0 to 200%) in 5% increments without modifying the controller's program duration; also can be used to fine-tune the preset ET program for each month

- Rain Delay with up to 99 days with auto restart

Specifications

- Power source: ambient light (solar)
- Controller power input: 3,000 - 100,000+ LUX
- Seven keypad buttons with an integrated liquid crystal display
- Operating pressure: 10-150 PSI (.7-10.3 BAR)
- Temperature range: 14°F to +130°F (-10°C to +54°C)
- Solenoid: 7-12 VDC, two-way latching, normally closed
- Solenoid control orifice: .065" (1.65 mm)
- Solenoid thread: 11/16"-12 UN male thread
- Retractable solenoid wire: 8.1" (coiled length when extended, approximately 36")
- Sensor connection: Normally closed 6" (15 cm) yellow wire (16 AWG)
- Controller with solenoid only includes adapters for Rain Bird, Hunter and Toro valves
- Valves type & sizes: globe 3/4", 1", 1 1/2" and 2"
- Valves type & sizes: anti-siphon in 3/4" and 1"
- Materials:
 - Controller housing: high-impact plastic
 - Solenoid housing: glass reinforced nylon
 - Plunger & spacer: 430F stainless
 - Plunger rubber cap: EPDM
 - O-ring: Buna-N
 - RoHS



How to specify

Model	Description
LEIT 1	Controller Only
See available valve adapters page 61	
LEIT 1 with Manual Valve Actuator	
LEIT 1 MVA	3/4"-1"
LEIT-1 with Inline Valve*	
LEIT 1 ILV-075	3/4"
LEIT 1 ILV-100	1"
LEIT 1 ILV-150	1.5"
LEIT 1 ILV-200	2"
LEIT-1 with Anti-siphon Valve*	
LEIT 1 ASV-075	3/4"
LEIT 1 ASV-100	1"



The LEIT 4000® is a self-contained, water-management irrigation controller that harnesses ambient light (solar) as a power source. The LEIT 4000 controller's easy-to-navigate features include four independent programs with three start times per day for each valve, password protected entry, monthly budgeting of up to 200%, rain delay of up to 99 days with automatic restart, manual run via the program or valve and status reports that include current and past month information for each valve. A compact and time-tested photovoltaic module powers the unit day and night in any kind of weather conditions.

A practical and affordable solution for

- Parks
- Cities
- Common Areas
- Zoos
- Highways
- Median Strips
- Mitigation sites
- Cemeteries
- Airports
- School Campuses

Features

- Operates four, six, or eight stations and a master valve or pump start without an AC power hookup, batteries or conventional solar panels (master valve or pump start replaces station eight when required)
- Non-volatile memory holds programs indefinitely without batteries
- Programming is easy using a self-guiding menu and four durable sealed buttons
- Multi-lingual software (Spanish, Italian, and French)
- Power is provided by an internal, ultra-high efficiency photovoltaic module and microelectronic energy management system fueled by ambient light
- USB port allows for software updates
- Lightning protection; the controller is fully isolated from electrical ground, offering virtual immunity to ground currents from overhead power lines and/or close proximity lightning strikes
- Simple to install, easy-access wire connector accommodates standard irrigation wire up to 12 gauge
- Environmentally friendly; uses clean, renewable solar power
- Assign rain, moisture or freeze sensors to an individual valve or to the entire system using an SKIT 8821-4 adapter
- Super tough lens protects the photovoltaic module from moisture, dust, chemicals and impact damage

Dimensions

- 9.4" H x 5.7" W x 3.2" D
(23.9 cm H x 14.5 cm W x 8.1 cm D)



How to specify

Model	Description
LEIT 4004	Four stations plus MV/P
LEIT 4006	Six stations plus MV/P
LEIT 4008	Eight stations including MV/P

Programming

- Four independent programs with three start times per program allow for mixed irrigation applications
- Custom program-scheduling using a weekly calendar, odd days, even days, or intervals from 1-30 days utilizing a yearly calendar with leap year
- Watering durations from 1 minute to 5 hours and 59 minutes
- Status Report for each valve verifies operating time for past and current month
- Rain delay up to 99 days with auto restart
- Water budgeting from 10-200% in 10% increments
- Vandal resistant, waterproof enclosure fashioned from super tough material

Controller Specifications

- Power source: ambient light (PVM)
- Controller power input: 3,000 – 100,000+ LUX
- Power output to the solenoid actuator: bidirectional (positive-negative) pulses @ 5 volts DC
- Station capacity: one LEMA 1600HE per each set of red and white wires
- USB port for software update: Type B
- Operational temperature: 14°F to 140°F (–10°C to 60°C)
- Storage temperatures range: –40°F to 194°F (–40°C to 90°C)
- Sensor connection: normally closed, none active
- Entry: LEIT key to energize the liquid crystal display (not included, uses a 9-volt battery)
- Material: Controller housing and clear lens: high-impact plastic (polycarbonate)

Security

- Programming password eliminates potential user error
- Password can be changed at any time during program setup activation
- Standard stainless-steel lock secures weather-resistant exterior panel



LEIT X & LEIT XRC

The LEIT XRC is an advanced, waterproof, wireless water-management controller powered by ambient light (solar). The controller's low power photovoltaic module collects light to produce pollution-free electricity which is stored and used to power the controller day and night in any kind of weather. The LEIT® XRC operates 4 to 28 zones without a connection to the power grid, delivering a cost-effective alternative to conventional AC control systems.

DIG's LEIT X with 10 to 28 stations supports a permanent solution where there is no available AC power, utilizing only the power of ambient light (solar). The LEIT X is an advanced, ambient light (solar) powered, self-contained water management irrigation controller that provides a cost-effective solution for all type of irrigation applications.

Controller Features

- Environmentally friendly, using light (solar) as a source of energy
- Power is provided by photovoltaic module (PVM) and microelectronic management system fueled by ambient light (solar)
- Operates up to 28 stations plus a master valve or pump start
- Used with the 1600HE solenoid actuator, which mounts on most brand name valves using one of seven valve adapters
- Remote programming and management capability using the LEIT Link remote control handset
- Radio frequency module operates in the ISM band 900-928 MHz US
- Communication distance of up to 800' (244 m) line of site
- Non-volatile memory retains program and controller integrity (excluding time)
- Bilingual software available in English-Spanish, English-Italian and English-French
- Lightning protection - the controller is isolated from electrical ground, offering immunity to ground currents from overhead power lines and/or close proximity lightning strikes
- Simple to install, easy-access wire connector accommodates standard irrigation wire up to 12 gauge
- Terminal strip can handle 28 hot wire stations, a MV/P wire and two common wires
- Can connect rain, moisture or freeze sensors to an individual

valve or to the entire system using an SKIT 8821-4 switch type sensor (adapter is required)

- Three-year manufacturer's warranty
- Vandal resistant, waterproof enclosure fashioned from super tough material that endures extreme hot, cold, wet or dry weather

Programming

- Four independent programs with three start times per program
- Custom program-scheduling using a weekly calendar, odd days, even days, or intervals from 1-30 days utilizing a yearly calendar with leap year
- Watering durations from 1 minute to 5 hours and 59 minutes
- Status report provides information on active programs or valves, month deactivations, rain stop, remote or local mode and station short circuit if activated
- Rain delay up to 99 days with auto restart
- Global monthly water budgeting from 10- 200% in 10% increments
- Custom grouping of stations allows the controller to operate any number of stations per group together in any of the programs (if hydraulic limitations are not exceeded)
- Manual run allows for repeat testing of individual valves, semi-automatic cycling by station with quick override via manual setup, or full program run
- History reports provide operating



How to specify

Model	Description
LEIT X system controller	
LEIT X10	10 stations plus MV/P
LEIT X12	12 stations plus MV/P
LEIT X16	16 stations plus MV/P
LEIT X20	20 stations plus MV/P
LEIT X24	24 stations plus MV/P
LEIT X28	28 stations plus MV/P
LEIT XRC system controller	
LEIT XRC04	4 stations plus MV/P
LEIT XRC06	6 stations plus MV/P
LEIT XRC08	8 stations plus MV/P
LEIT XRC10	10 stations plus MV/P
LEIT XRC12	12 stations plus MV/P
LEIT XRC16	16 stations plus MV/P
LEIT XRC20	20 stations plus MV/P
LEIT XRC24	24 stations plus MV/P
LEIT XRC28	28 stations plus MV/P
LEIT Link remote control handset	
LEIT MULTI-PRO™	up to 99 controllers
LEIT MASTER™	99 controllers with 99 groups

history on each valve with total programmed watering time and total manual run time. This information is available for the current month and the previous 11 months, and the current year versus the previous year

- Monthly off option allows shut-off of irrigation for any month of the year. All months are active by default
- Open or short circuit detection allows the controller to detect shorts and/or open wires. The short and open valve test is deactivated by default.

Controller Specifications

- Power source: ambient light (PVM)
- Controller power input: 3,000 -100,000+LUX
- Number of stations:
Model LEIT X: 10, 12, 16, 20, 24 and 28 station plus MV/P
- Four keypad buttons with integrated liquid crystal display

Remote Control Handset

The MULTI-PRO™ remote control handset allows the user to operate the LEIT XRC from a distance of up to 800 feet line of site. The handset allows the user to review, test and manage any number of LEIT XRC controllers on the site. It also incorporates all the features and software flow of the LEIT XRC controller. The handset allows the user a wide range of flexibility using wireless communication.

Handset Specifications

- MULTI-PRO™ Remote Control Handset: communicate with up to 99 controllers with the same secure ID code
- Radio frequency: radio module operates in the ISM band 900-928 MHz US and Australia (866/869 MHz Europe)
- Battery recharge: up to four hours of continuous operation
- Remote handset Input: 12-volts using 3.6-volt Nim/MH rechargeable cell battery pack
- Remote handset wall charger: 120AVC/60 H2, 12-volt DC @ 250 mA (included)
- FCC approved, part 15 of FCC rules for spared spectrum, international radiators, and part 15 sub C specification
- Dimensions: 4" W x 8.6" H (10.1 cm W x 21.8 cm H)
- Material: UV-resistant, high-impact plastic



- Power output to the solenoid actuator: bi-directional (positive-negative) pulses @ 5 volts DC
- Station capacity: one LEMA 1600HE per each set of red and white wires
- Radio frequency: radio module operates in the ISM band 900-928 MHz US and Australia (866/869 MHz Europe)
- Operational temperature: 14°F to 140°F (-10°C to 60°C)
- Storage temperatures range: -40°F to 194°F (-40°C to 90°C)
- Sensor connection: normally closed, none active
- Entry: LEIT key to energize the liquid crystal display not included
- Controller dimensions: 12.4" (31.5 cm) H x 7.5" (19.1 cm) W x 4.5" (11.4 cm) D
- Weight: 4.9 lbs. (2.2 kg)
- FCC approved, part 15 of FCC rules for spared spectrum, international radiators, and part 15 sub C specification

- Materials: controller housing and clear lens - high-impact plastic (polycarbonate)

Security

- Programming password eliminates potential error by another user
- Password can be changed at any time during program setup
- Standard stainless-steel lock secures weather resistant exterior panel



Programming Features

The MULTI-PRO™ handset can read status reports, modify settings and temporarily interrupt a running program to do a manual run, test a valve or skip to the next valve. When connecting to a LEIT XRC, the current running program and current open valve information is provided on first contact. Then, in status mode, the handset can review time, date, revised budgets, sensor activation (if rain stop is active), and solenoid and wire integrity. In the history report, it can review hourly usage on each valve for a period of up to two months.

LEIT Key

Features

- Prevents unauthorized access to the controller's schedule and programs
- Used to power the display of the LEIT 4000, LEIT X and LEIT XRC

Specifications

- Power: 9-volt battery



How to specify

Model	Description
LEIT KEY	Programming tool for LEIT 4000, X, XRC controllers

Switch Type Sensor Adapter

Features

- Waterproof construction
- Easy to install
- Adapts to a wide range of sensors

Specifications

- Compatible with normally closed switch-type sensors only
- Comes with 12" 12-gauge wire
- Weight: approx. 2 oz (56 g)
- Length: approx. 1.9" (4.8 cm)
- Diameter: approx. 1.1" (2.8 cm)



How to specify

Model	Description
SKIT8821-4	Sensor adapter for LEIT 4000, X, XRC

Sensor Recommendation

- Recommended rain sensors are the Hunter Mini-Click and the Rain Bird RSD
- Recommended moisture sensor is the Irrrometer WEM-B
- Recommended freeze sensor is the Hunter Freeze Click

Relay Interface Kit

Features

- Waterproof construction
- Easy to install
- Adapts to a wide range of sensors
- For use with LEIT 4000, X and XRC series controllers only
- Enables a LEIT controller to actuate pumps and other AC/DC equipment

Specifications

- High power V2 pulse input
- Rated load 10A, 250 AC or 30V DC
- Maximum voltage 380 VAC 125 VDC
- Weight: approx. 8 oz (220 g)
- Length: approx. 1.25" (3.18 cm)
- Diameter: approx. 0.75" (1.91 cm)



How to specify

Model	Description
RKIT-8810S	Relay interface module for 24 AC/DC-230V AC/DC (for 4000, X, & XRC)

Mounting Columns

Features

- Mounting columns are available with two different ODs: small OD for the 4000 series and larger OD for the LEIT X series
- Includes mounting kit

Specifications

- 4000-Series column weight:
 - Short: approx. 9 lbs (4.1 kg)
 - Long: approx. 13.5 lbs (6.1 kg)
- X-Series column weight:
 - Short: approx. 11 lbs (5 kg)
 - Long: approx. 14 lbs (6.4 kg)
- Material: Galvanized steel



How to specify

Model	Description
MCOL-4000	Mounting column 32" (81 cm) short
MCOL-4000L	Mounting column 48" (122 cm) long
MCOLXS	Mounting column 35" (89 cm) short
MCOLXL	Mounting column 51" (130 cm) long
MKIT 4000	Column mounting kit for LEIT 4000
MKIT X	Column mounting kit for LEIT X & XRC

Stainless-Steel Enclosures

Features

- Manufactured using the highest quality stainless steel
- Weatherproof, rustproof and extremely durable
- Grid design on top ensures light access to photovoltaic module
- Easy to install with a standard 3/8" socket wrench
- Installation of the enclosure does not require the controller to be removed or modified in any way
- Airflow holes on the top and bottom of each enclosure control the temperature inside
- Each enclosure comes with a high security stainless-steel disc lock to ensure only authorized access to the controller

Specifications

- 4000-Series weight: 6.2 lbs (2.8 kg)
- X-Series weight: 10.9 lbs (5 kg)
- 14 AWG 304 stainless-steel case

Dimensions

- 4000 Series dimensions:
 - * 10.8" H x 7.5" W x 3.8" D
(27.4 cm H x 19.1 cm W x 9.7 cm D)
- X Series dimensions:
 - * 14" H x 8.7" W x 6" D
(35.6 cm H x 22.1 cm W x 15.2 cm D)



How to specify

Model	Description
ENCL-X	LEIT X and XRC series stainless-steel enclosure
ENCL-4000	LEIT 4000 series stainless-steel enclosure

Solenoids, Valves and Actuators



DIG's comprehensive line-up includes valve actuators, inline (globe) valves and heavy duty anti-siphon valves; all are equipped with reliable LEMA actuators and AC or DC latching solenoids, and are available in sizes from 3/4" to 2".

LEMA 1600HE actuators (for LEIT 4000 and X-series controllers) and S-305DC solenoids (for LEIT-2ET and 700A-series controllers) can be installed on a wide range of solenoid valves by using one of DIG's 30-9XX adapters.



62

LEMA Solenoid & Valve



63

S-305DC Solenoid



63

Solenoid Adapters



64

305DC Inline Valves, Anti-siphon Valves & Actuator



65

DC Remote Control Valves



66

24VAC Inline Valve, Anti-siphon Valve & Actuator



67

24VAC Remote Control Valve



67

24VAC Solenoids



68

DC Relay

LEMA 1600 DC Solenoid and 160HE DC Inline Valve

Features

- Designed to work with LEIT 4000, LEIT X and XRC controllers only
- Adaptable to a wide range of valves using DIG's valve adapters
- Potted design for sealed construction
- Captured plunger and spring for reliable operation

Inline Valve Features

- Internal bleed, manual override for manual ON/OFF
- Constructed of glass reinforced nylon with a stainless-steel spring; non-corrosive materials
- High flow with low pressure loss
- Normally closed
- Easy in-line maintenance
- Smooth valve opening and closing prevents pressure surge hazards
- Rugged, reinforced self-cleaning diaphragm provides reliable operation even with contaminated water
- Flow control handle for water flow adjustment and manual shutoff
- Manual internal bleed override

Specifications

- Pressure range: 10-125 PSI (.7-10.3 BAR)
- Weight: 5.3 oz (148 g)
- Temperature range: up to 150°F (65°C)
- Control orifice: .065" (1.7 mm)
- Leads: 18" (46 cm) AWM 1007/ 1569 16 AWG 300V VW-1 red and white wires
- Materials:
 - Solenoid: glass reinforced nylon
 - Inside plunger & spacer: 430F stainless
 - Plunger rubber cap: EPDM
 - O-ring: Buna-N
- Length: 3.08" (7.8 cm)



How to specify

Model	Description
	For use with LEIT 4000, X, XRC controllers only
LEMA 1600HE	Solenoid with internal bleed manual override
160HE-075	LEMA 1600HE on 3/4" inline valve
160HE-100	LEMA 1600HE on 1" inline valve
160HE-150	LEMA 1600HE on 1 1/2" inline valve
160HE-200	LEMA 1600HE on 2" inline valve



Maximum Wire Run

For Use with LEIT 4000, X and XRC Controllers

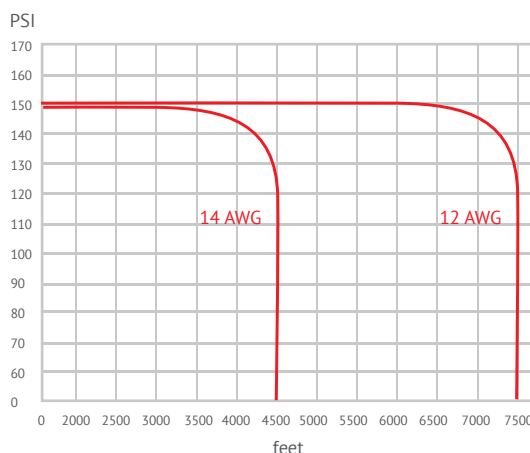

S-305DC 12VDC Solenoid

Features

- Designed to work with a single- and multi-station battery operated controller and LEIT-2 ET solar powered controller
- Adaptable to a wide range of valves using our valve adapters
- Potted design for sealed construction
- Two color-coded wires
- Captured plunger and spring for reliable operation

- Diameter: 1.23" (3.1 cm)
- Materials:
 - Body: glass-reinforced nylon
 - Plunger & Spacer: 430F stainless steel
 - Rubber cap: EPDM
 - O-ring: Buna-N



Electrical Specifications

- Two-way magnetic latching solenoid
- Coil operating data:
 - Coil resistance 4.7 +/- 0.3 Ohms, minimum pulse 10 mS duration at 7-12 volts
 - Red + and white - to latch open
 - Red - and white + to latch closed
- Control orifice: .065" (1.7 mm)
- Leads: 18" (46 cm) AWM 1007 / 1569 16 AWG 300V VW-1- red/white

Specifications

- Operating pressure: 10-150 PSI (7-10.5 BAR)
- Weight: 4.3 oz (122 g)
- Temp. range: 38°F to 150°F (3°C to 65°C)
- Solenoid thread: 11/16"-12 UN
- Control orifice: .065" (1.7 mm)

How to specify

Model	Description
For use with LEIT-2 ET & 700A Series controllers only	
S-305DC	DC Solenoid (7-12 volt) with 11/16"-12 UN thread
S-305DC-10	DC Solenoid (7-12 volt) with 11/16"-12 UN thread (pack of 10)
S-305DCA	DC Solenoid (7-12 volt) with 11/16"-12 UN thread and four adapters for DIG, Rainbird, Toro and Hunter

Valve/Solenoid Adapters

Features

- For use in conjunction with the S-305DC and 1600HE DC solenoids
- Can be used with most brand name valves
- Made of durable plastic
- Female thread: 11/16"-12 UN



Materials

- Adapter: nylon
- O-ring: Buna-N
- Sleeve: vinyl

How to specify

Model	Description
For use with LEMA 1600HE and S-305DC solenoids only	
30-920	BERMAD series 200, HIT series 500, DOROT series 80, GRISWOLD series 2000, DW and BUCKNER series VB valves
30-921	RAIN BIRD DV, DVF, PGA, PEB (1" only), GB, EFB-CP, BPE, PESB (1" only) and ASVF valves
30-922	HUNTER series ASV, HPV, ICV, PGV, SRV, IBV and ASVF valves
30-923	WEATHERMATIC series 12000, 21000 and 8200CR valves
30-924	IRRITROL series 100, 200B, 205, 217B, 700, 2400, 2500 and 2700 valves, and TORO series 220 and P220 valves
30-925	SUPERIOR series 950, HUNTER HBV and TORO series 252 valves (1.5" and larger)
30-926	RAIN BIRD series PEB and PESB valves

305DC Inline Valves, Anti-siphon Valves and Actuator



Actuator

Features

- Contains all parts required to convert most 3/4" and 1" brass or plastic manual anti-siphon valves
- Built-in flow control
- Internal or external manual bleed override for manual ON/OFF
- Smooth valve opening and closing prevents pressure surge hazards
- High flow with low pressure loss
- Normally closed
- Easy in-line maintenance
- Constructed of glass reinforced nylon with a stainless-steel spring; non-corrosive materials

How to specify

Model	Description
Use with 740.000 and 746.000 DC controllers	
305DC-013	DC solenoid with 3/4" or 1" actuator



3/4" and 1" Anti-siphon Valve

Features

- Anti-siphon valve combines a remote control valve and backflow preventer in one unit
- Constructed of UV-resistant, glass reinforced nylon bonnet with a stainless-steel spring and non-corrosive materials
- High flow with low pressure loss
- Operates in a wide range of flow rates
- Flow control handle for water flow adjustment and manual shutoff
- External or internal manual bleed allows quick and easy valve opening and closing
- Excellent leak-free performance utilizing self-cleaning EPDM diaphragm and seal design assembly
- Encapsulated EPDM seal washer built-in into the atmospheric backflow assembly
- Manual or automatic operation
- Encapsulated solenoid plunger for quick and easy service and maintenance

How to specify

Model	Description
For use with LEIT-2 controllers only	
305DC-ASV-075	3/4" ASV with S-305DC solenoid
305DC-ASV-100	1" ASV with S-305DC solenoid



3/4" - 2" Inline Valve

Features

- Constructed of glass reinforced nylon with a stainless-steel spring; non-corrosive materials
- High flow with low pressure loss
- Normally closed
- Easy in-line maintenance
- Smooth valve opening and closing prevents pressure surge hazards
- Rugged, reinforced self-cleaning diaphragm provides reliable operation even with contaminated water
- Flow control handle for water flow adjustment and manual shutoff
- Manual internal bleed override via the solenoid

How to specify

Model	Description
For use with LEIT-2 ET & 700A Series controllers only	
305DC-075	DC solenoid on 3/4" inline valve
305DC-100	DC solenoid on 1" inline valve with flow control
305DC-150	DC solenoid on 1 1/2" inline valve
305DC-200	DC solenoid on 2" inline valve

Remote Control Valves with 6 to 12 VDC Latching Solenoid

Remote Control Valves with 6 to 12 VDC Latching Solenoid



Features

- Designed for reliable operation and excellent hydraulic performance
- Features a flow control handle for flow adjustment and manual shutoff to zero
- Compact design with minimal space
- Internal and external manual opening
- Uses an encapsulated, watertight, two-way, 6 to 12 VDC magnetic latching solenoid
- Available in ¾" and 1" globe style
- Rugged, reinforced self-cleaning diaphragm provides reliable operation
- Balanced diaphragm supported by SS spring allows for low opening pressure and secured closing
- High impact nylon reinforced body and cover
- High durability to chemical use with an irrigation system

Specifications

- Body style: inline (globe) valve
- Operating pressure: 10 to 150 PSI (.7 to 10.5 bar)
- Valve sizes: ¾" and 1" with FNPT or British standard thread (BSP)
- Available with flow control or without
- Temperature range: up to 135° Fahrenheit (0-57° C)
- Operating flow range:
 - ¾" size: .1 to 20 GPM (.23 to 4.54 m3h)
 - 1" size: .2 to 35 GPM (0.45 to 8 m3h)

Note: For drip applications, use a minimum of 150 mesh screen or disc filter installed upstream

- Solenoid: 6 -12 VDC, two-way magnetic latching, normally closed, bidirectional pulse
 - Voltage rate: 6 -12 VDC
 - Coil resistance: 4.7Ω +/- 0.3
 - Pulse width: minimum 10 mSec
 - Operation mode:
 - Red + white: latch to open
 - Red - white: released to closed



How to specify

Model	Description
300DC-075	¾" FPT, 24 VAC globe valve with flow control, internal and external manual bleed
300DC-100	¾" FPT, 24 VAC globe valve with flow control, internal and external manual bleed
300DC-075BSP	¾" BSP, 24 VAC globe valve with flow control, internal and external manual bleed
300DC-100BSP	¾" BSP, 24 VAC globe valve with flow control, internal and external manual bleed

24VAC Inline Valve, Anti-siphon Valve & Actuator



Manual Valve Actuator

Features

- Built-in flow control
- Internal or external manual bleed override for manual ON/OFF
- Smooth valve opening and closing prevents pressure surge hazards
- Constructed of glass reinforced nylon with a stainless steel spring and non-corrosive materials
- High flow with low pressure loss
- Normally closed
- Easy in-line maintenance

Specifications

- Operating pressure: 20 to 150 PSI (1.4 - 10.3 BAR)
- Water temperature range: up to 110°F (43°C)
- Body & cover: glass reinforced nylon
- Diaphragm: EPDM
- Metal parts and screws: stainless steel 18-8
- O-ring: Buna-N

How to specify

Model	Description
For use with AC controllers only	
33-AC-MVA	Actuator with AC solenoid



Anti-siphon Valve

Features

- Anti-siphon valve combines a remote control valve and backflow preventer in one unit
- Constructed of a UV-resistant, glass reinforced nylon bonnet with a stainless-steel spring and non-corrosive materials
- High flow with low pressure loss
- Operates in a wide range of flow rates
- Flow control handle for water flow adjustment and manual shutoff
- External or internal manual bleed allows quick and easy valve opening and closing
- Excellent leak-free performance utilizing self-cleaning EPDM diaphragm and seal design assembly
- Encapsulated EPDM seal washer built into the atmospheric backflow assembly
- Manual or automatic operation
- Encapsulated solenoid plunger for quick and easy service and maintenance

How to specify

Model	Description
33-AC-ASV-075	3/4" ASV with 24VAC solenoid
33-AC-ASV-100	1" ASV with 24VAC solenoid



Inline Valve

Features

- Solenoid thread: 3/4"-20 UNES-2A
- Internal bleed, manual override for manual ON/OFF
- High flow with low pressure loss
- Rugged, reinforced self-cleaning diaphragm provides reliable operation even with contaminated water
- Flow control handle for water flow adjustment and manual shutoff
- Low sensitivity to dirt and voltage fluctuations
- Replaceable plunger tip
- Silicone O-ring
- Heavy-duty construction

Electrical Specifications

- Current: .25 (7.7 VA)
- Holding current: 0.125A (3.84 VA)
- Power consumption: 1.7/2.2 watts
- Solenoid: 24VAC (50-60 cycles)
- Solenoid thread: 3/4"-20 UNES-2A

How to specify

Model	Description
For use with AC controllers only	
33-001	3/4" inline valve with solenoid no flow control
33-002	1" inline valve with solenoid no flow control
33-014	3/4" inline valve with solenoid
33-015	1" inline valve with solenoid
33-016	1 1/2" inline valve with solenoid
33-017	2" inline valve with solenoid

24VAC Inline Valves

24 VAC Remote Control Valves



Features

- Designed for reliable operation and excellent hydraulic performance
- Features a flow control handle for flow adjustment and manual shutoff to zero
- Internal and external manual opening
- Available in 3/4" and 1" globe style
- Rugged, reinforced self-cleaning diaphragm provides reliable operation
- High impact nylon reinforced body and cover
- Highly durability to chemical use with an irrigation system

Specifications

- Body style: inline (globe) valve
- Operating pressure: 10 to 150 PSI (.7 to 10.5 bar)
- Valve sizes: 3/4" and 1" with FNPT or British standard thread (BSP)
- Available with flow control or without
- Temperature range: up to 135° Fahrenheit (0-57° C)
- Operating flow range:
 - 3/4" size: .1 to 20 GPM (.23 to 4.54 m3h)
 - 1" size: .2 to 35 GPM (0.45 to 8 m3h)

Note: For drip applications, use a minimum of 150 mesh screen or disc filter installed upstream

- Solenoid: 24 VAC (50 -60 cycles)
 - Current: .032A (7.7 VA)
 - Holding current: 0.16A (3.84 VA)
 - Power consumption: 1.7/2.2 watts
- Material:
 - Body: glass-reinforced nylon
 - Bonnet: glass-reinforced nylon
 - Solenoid: glass-reinforced nylon
 - Spring and pins: Stainless steel
 - Diaphragm: Nitrile rubber (NBR)



How to specify

Model	Description
170SV-075	3/4" FPT, 24 VAC globe valve with flow control, internal and external manual bleed
170SV-100	3/4" FPT, 24 VAC globe valve with flow control, internal and external manual bleed
170SV-075BSP	3/4" BSP, 24 VAC globe valve with flow control, internal and external manual bleed
170SV-100BSP	3/4" BSP, 24 VAC globe valve with flow control, internal and external manual bleed

24VAC Solenoid

Features

- Low sensitivity to dirt and voltage fluctuations
- Replaceable plunger tip
- Silicone O-ring
- Heavy-duty construction

Electrical Specifications

- Current: .25 (7.7 VA)
- Holding current: 0.125A (3.84 VA)
- Power consumption: 1.7/2.2 watts
- Solenoid: 24VAC (50-60 cycles)
- Solenoid thread: 3/4"-20 UNES-2A



How to specify

Model	Description
33-005	3/4"-20 thread 24VAC solenoid

RIK-018

General purpose relay interface DC latching switch type module.

Features

- Used for operation of pump fertilizer injector, fountain, light or any electrical equipment
- Can be used with 720A, 740A and 760A
- RoHS Compliant

Specifications

- Relay function: Single coil latching
- Input Voltage: Rated 3V DC
- Input Rated Current: 67mA
- Input Minimum Set/Reset Signal Width: 20 mili Second at 23 Degrees C

- Input Coil Resistance: 45 Ohms
- Contact Rated Load: 10Amp and 250VAC, or 10Amp 30V DC
- Contact Maximum Carrying Current: 10 Amps
- Contact Maximum Resistance: 30 milliOhm
- Insulation Resistance: 1,000 Mega Ohms
- Weight: 50g, or 1.76oz
- Length of Input (red, white) and Output (black, black) wires: 18" (46 cm)



RIK-018 Wiring Diagram to 700A series Multi-Station DC Controllers

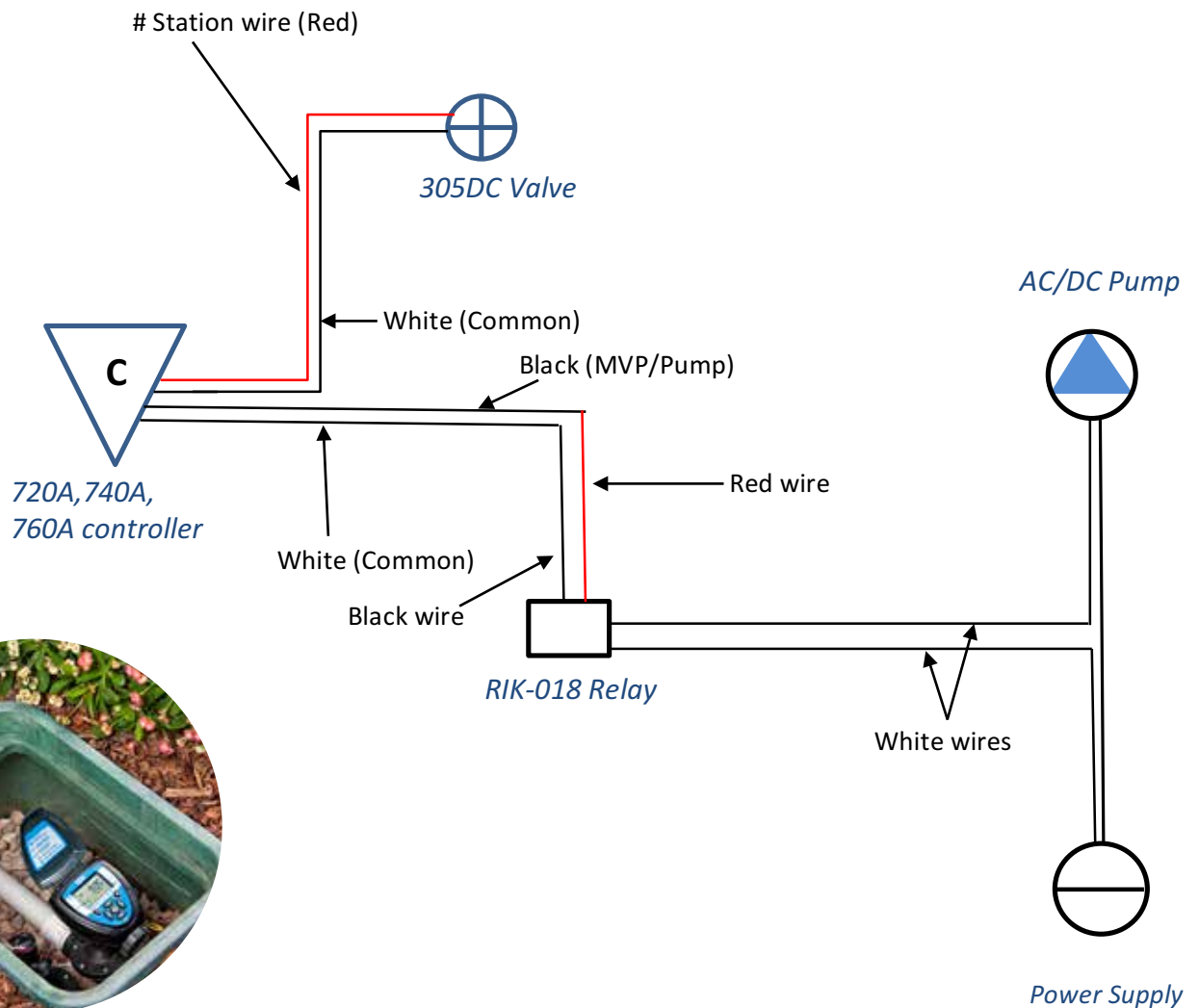

Inline Valve Pressure Loss & Specifications

Performance pressure loss (PSI)				
Flow Rate (GPM)	Size			
	3/4"	1"	1 1/2"	2"
5	3	3	-	-
9	3.5	3	-	-
13	4.2	4	-	-
18	6	4.5	-	-
20	-	-	2.5	-
22	7.2	5	-	-
26	8.5	5.5	-	-
31	-	7	-	-
35	-	8.5	2.8	2.7
45	-	-	3.2	2.8
55	-	-	3.2	3.1
65	-	-	4.2	4.3
90	-	-	5.0	5.3
120	-	-	6.6	6
132	-	-	8.5	8.5
154	-	-	-	9.1
160	-	-	-	-

Performance pressure loss (BAR)				
Flow Rate (m ³ /h)	Size			
	3/4"	1"	1 1/2"	2"
1	0.21	0.20	-	-
2	0.25	0.23	-	-
3	0.30	0.28	-	-
4	0.42	0.33	-	-
5	-	-	0.19	-
6	0.60	0.39	-	-
7	-	0.51	-	-
8	-	0.60	0.20	0.18
10	-	-	0.22	0.19
13	-	-	0.23	0.20
15	-	-	0.30	0.22
20	-	-	0.35	0.30
27	-	-	0.46	0.37
30	-	-	0.60	0.42
35	-	-	-	0.60
36	-	-	-	0.64
-	-	-	-	-

Specifications Inline valve
<ul style="list-style-type: none"> Flow rate: <ul style="list-style-type: none"> 3/4": .1-28 GPM (.23-6.4 m³/h) 1": .2-35 GPM (0.45-8 m³/h) 1 1/2": 20-132 GPM (4.5-30 m³/h) 2": 30-160 GPM (6.8-36 m³/h) Operating pressure: 10-150 PSI (.7-10.3 BAR) Temperature range: up to 170°F (76.2°C) Body style: globe 3/4", 1", 1 1/2" and 2" FNPT inlet and outlet

Anti-siphon Valve Pressure Loss & Specifications

Specifications anti-siphon valve
<ul style="list-style-type: none"> Pressure range: 20 to 150 PSI (1.4 - 10.3 BAR) 3/4" ASV flow rate: .25 to 20 GPM (.95-76 LPM) 1" ASV flow rate: .25 to 25 GPM (.95-95 LPM) Body: rigid PVC Bonnet: glass reinforced nylon Water temperature range: up to 110° F (43° C) Listed compliances: UPC City of Los Angeles and Canadian Standards Association listing approved Centerline distance: 3.75" (9.5 cm)

Performance pressure loss (PSI)		
Flow rate (GPM)	Size	
	3/4"	1"
5	4.00	4.00
10	5.00	5.00
15	6.50	7.00
20	8.75	9.25
25	12.25	12.75
30	18.50	19.00

Manual Valve Actuator Specifications

Specifications manual valve actuator
<ul style="list-style-type: none"> Operating pressure: 20-125 PSI Temperature range: up to 150°F (65.5°C) Body & Cover: glass reinforced nylon Diaphragm: EPDM Metal parts and screws: <ul style="list-style-type: none"> stainless steel 303 O-ring: Buna-N

Conversion Charts, Area Equivalents & Units of Measure

Conversion charts

To Convert	Into	Multiply By
Flow rate		
US GPH	Liter/Hour	3.785
US GPM	Liter/Hour	227.1
US GPM	Cubic Feet/Second	0.002228
US GPM	m ³ /Hour	.2273
Liter/Second	US GPM	15.85
Liter/Second	US GPM	951.002
Liter/Second	m ³ /Hour	3.6
Liter/Hour	US GPM	0.26417
Liter/Hour	US GPM	0.004403
m ³ /h	US GPM	4.40288
Cubic Feet/Sec.	m ³ /h	101.9
m ³ /h	Cubic Feet/Second	0.00981
Cubic Feet	Gallons	7.4805

Pressure/head

PSI	BAR	0.07031
PSI	Meter	0.7031
PSI	Feet	2.307
Feet	ATM	0.02919
Feet	PSI	0.4335
Feet	BAR	0.03048
Meter	PSI	1.422
Meter	ATM	0.0967
ATM	BAR	1.0336
ATM	Meter	10.336
ATM	BAR	1.01365
ATM	PSI	14.7
BAR	PSI	14.504
BAR	ATM	0.9865
BAR	BAR	1.0197
BAR	PSI	14.223
BAR	Feet	32.81

Weight

Ounce	Gram	28.36
Lbs	Ounce	16
Kg	Lbs	2.20464

Energy

Foot Candle	Lux	10.764
-------------	-----	--------

Temperature

Celsius	Fahrenheit	(1.8) + 32
Fahrenheit	Celsius	(F-32): 1.8

To Convert	Into	Multiply By
Length		
Inch	Feet	0.08333
Feet	cm	30.48
Feet	Yard	0.3333
Yard	Meter	0.9144
Mile	Meter	1609.344
Mile	Yard	1760
Inch	cm	2.54
mm	Inch	0.03937
Meter	Inch	39.3701
cm	Inch	0.3937
cm	Yard	0.1094
cm	Feet	0.03281
cm	Meter	0.01
cm	Milimeter	10

Area

Square Inch	Square Feet	0.00694
Square Inch	Square cm	6.4516
Square Feet	Square cm	929.03
Square Feet	Square Meter	0.0929
Square Feet	Square Inch	144
Square Yard	Square Meter	0.836
Square Yard	Square Inch	1296
Square Yard	Square Feet	9
Square Mile	Square km	2.59
Square Mile	Acre	640
Acre	Square Feet	43560
Acre	Square Yard	4840
Square cm	Square Inch	0.155
Square Meter	Square Feet	10.7639
Square Meter	Square Yard	1.196
Square km	Square Mile	0.3861
Acre	Hectare	0.404686
Acre	Square Meter	4047

Volume

US Gallon	Cubic Inch	231
US Gallon	Cubic Feet	0.13368
US Gallon	Liter	3.7854
US Gallon	Cubic Meter	0.0037854
US GPM	m ³ /h	0.22715
Cubic Inch	Cubic cm	16.3871
Cubic Inch	US Gallon	0.004329
Cubic Feet	Cubic Inch	1728
Cubic Feet	Liter	28.32
Cubic Meter	US Gallon	264.172
HP/US	HP/Metric	1.014
HP/Metric	HP/US	0.986
HP/US	Kilowatt	0.7457
Acre - Feet	Square Feet	325,851
Acre - Feet	Cubic feet	43560
Acre - Feet	Meter (Cubed)	1233.5

Area equivalents

1 Acre = 43,560 Sq. Ft = 4840 Yd 2 = 0.4047 Hectares
= 160 Sq. Rods = 4047 m 2 = 0.0016 Sq. Mile

1 Acre-Inch = 102.8 m 3 = 27,154 Gal. = 3630 Ft. 3

1 Hectare (HA) = 10,000 m 2 =
100 Acre = 2.471 Acres = 107,639 Sq. Ft.

1 Cubic Foot (Ft. 3) = 1728 In. 3 =
0.037 Yd. 3 = 0.02832 m 3 = 28, 320 cm 3

1 Square Foot (Ft. 2) = 144 In. 2 =
929.03 cm 2 = 0.9290 m 2

1 Square Yard (Yd. 2) = 9 Ft. 2 = 0.836 m 2

1 Cubic Yard (Yd. 3) = 27 Ft. 3 = 0.765 m 3

Flow equivalents

1 GPM = 0.134 Ft. 3/Minute

1 Ft. (Cubed)/min (CFM) =
449 Gal./Hr. (GPH) = 7.481 Gal. Min.

Units of measure

UNITS	Sq. In.	Sq. Ft.	Sq. Yd.	Sq. cm	Sq. m
Sq. In.	1	0.006944	0.0007716	6.452	0.000645
Sq. Ft.	144	1	0.1111	929	0.0929
Sq. Yd.	1296	9	1	8361	0.8361
Sq. cm	0.155	0.001076	0.0001196	1	0.0001
Sq. m	1550	10.76	1.196	10.000	1

Head Loss Charts

Friction loss charts

Polyethylene (Pe) tubing

Size ID OD Wall Thick	1/2"		1/2"		1/2"		5/8"		3/4"		1"	
	Vel. FPS	PSI Loss	Vel. FPS	PSI Loss	Vel. FPS	PSI Loss	Vel. FPS	PSI Loss	Vel. FPS	PSI Loss	Vel. FPS	PSI Loss
0.25	0.38	0.09	0.28	0.04	0.27	0.04	0.02	0.02	0.15	0.01	0.09	0.00
0.50	0.75	0.32	0.57	0.16	0.53	0.14	0.39	0.07	0.30	0.02	0.18	0.01
0.75	1.13	0.68	0.85	0.34	0.80	0.29	0.59	0.14	0.44	0.07	0.27	0.02
1.00	1.51	1.17	1.13	0.58	1.06	0.50	0.79	0.24	0.59	0.12	0.36	0.04
1.25	1.89	1.76	1.42	0.88	1.33	0.75	0.98	0.36	0.74	0.18	0.45	0.06
1.50	2.26	2.47	1.70	1.23	1.59	1.05	1.18	0.51	0.89	0.25	0.54	0.08
1.75	2.64	3.29	1.98	1.64	1.86	1.40	1.38	0.67	1.04	0.24	0.64	0.10
2.00	3.02	4.21	2.27	2.10	2.12	1.79	1.57	0.86	1.18	0.42	0.73	0.13
2.25	3.39	5.23	2.55	2.61	2.39	2.22	1.77	1.07	1.33	0.54	0.82	0.16
2.50	3.77	6.36	2.83	3.17	2.65	2.70	1.97	1.31	1.48	0.65	0.91	0.20
2.75	4.15	7.59	3.12	3.78	2.92	3.22	2.16	1.56	1.63	0.78	1.00	0.24
3.00	4.53	8.91	3.40	4.44	3.18	3.79	2.36	1.83	1.78	0.92	1.06	0.28
3.25	4.90	10.34	3.68	5.15	3.45	4.39	2.56	2.12	1.92	1.06	1.18	0.32
3.50	5.28	11.86	3.91	5.91	3.71	5.04	2.75	2.43	2.07	1.22	1.27	0.37
3.75	5.66	13.48	4.25	6.72	3.98	5.73	2.95	2.77	2.22	1.38	1.36	0.42
4.00	6.04	15.19	4.53	7.57	4.25	6.45	3.15	3.12	2.37	1.56	1.45	0.47
4.50	6.79	18.89	5.10	9.41	4.78	8.03	3.54	3.88	2.67	1.94	1.63	0.59
5.00	7.54	22.96	5.67	11.44	5.31	9.76	3.94	4.71	2.96	2.36	1.82	0.72
5.50	8.30	27.39	6.23	13.65	5.84	11.64	4.33	5.62	3.26	2.91	2.00	0.86
6.00	9.05	32.18	6.80	16.04	6.37	13.67	4.72	6.61	3.55	3.31	2.18	1.01
6.50	9.81	37.32	7.37	18.60	6.90	15.86	5.12	7.66	3.85	3.84	2.36	1.17
7.00	10.56	42.82	7.93	21.34	7.43	18.19	5.51	8.79	4.15	4.40	2.54	1.34
7.50	11.32	48.65	8.50	24.25	7.96	20.67	5.90	9.99	4.44	5.00	2.72	1.52
8.00	12.07	54.83	9.07	27.33	8.49	23.30	6.30	11.25	4.74	5.63	2.90	1.71
8.50	12.83	61.34	9.63	30.57	9.02	26.06	6.69	12.59	5.03	6.30	3.09	1.92
9.00	13.58	68.19	10.20	33.99	9.55	28.98	7.08	14.00	5.55	7.01	3.27	2.13
9.50	14.33	75.37	10.77	37.57	10.08	32.03	7.48	15.47	5.63	7.75	3.45	2.36
10.0	15.09	82.88	11.33	41.31	10.61	35.22	7.87	17.01	5.92	8.52	3.63	2.59
11.0	16.60	98.89	12.47	49.29	11.68	42.02	8.66	20.30	6.51	10.16	3.99	2.09
12.0	18.11	116.2	13.60	57.90	12.74	49.36	9.44	23.85	7.11	11.94	4.36	3.63
13.0	19.62	134.7	14.73	67.16	13.80	57.25	10.23	27.66	7.70	13.85	4.72	4.21
14.0			15.81	77.04	14.86	65.67	11.02	31.72	8.29	15.88	5.08	4.83
15.0			17.00	87.54	15.92	74.63	11.81	36.05	8.88	18.05	5.45	5.49
16.0			18.13	98.65	16.98	84.10	12.59	40.63	9.48	20.34	5.81	6.19
18.0					19.11	104.6	14.17	50.53	10.66	25.30	6.54	7.69
20.0							15.74	61.42	11.84	30.75	7.26	9.35
22.0							17.31	73.27	13.03	36.68	7.99	11.16
24.0							18.89	86.08	14.21	43.10	8.71	13.11
26.0									15.40	49.99	9.44	15.20
28.0									16.58	57.34	10.17	17.44
30.0									17.77	65.15	10.89	19.82
32.0									18.95	73.43	11.62	22.33
34.0											12.35	24.99
36.0											13.07	27.78
38.0											13.80	30.70
40.0											14.52	33.76
42.0											15.25	36.95
44.0											15.98	40.28
46.0											16.70	43.74
48.0											17.43	47.32
50.0											18.16	51.04
55.0											19.97	60.89
60.0												
65.0												
70.0												

Distribution tubing

Size ID OD Wall Thick	1/8" Vinyl		1/4" Vinyl		1/4" Poly		
	Vel. FPS	PSI Loss	Vel. FPS	PSI Loss	Vel. FPS	PSI Loss	
0.05	3.0	1.3	4.77	0.8	1.62	0.7	1.07
0.10	6.0	2.6	17.20	1.6	5.86	1.4	3.86
0.15	9.0	3.9	36.45	2.5	12.4	2.1	8.16
0.20	12.0	5.2	62.06	3.3	21.12	2.8	13.90
0.25	15.0	6.5	93.77	4.1	31.91	3.5	21.01
0.30	18.0	7.8		5.0	44.71	4.2	29.43
0.35	21.0	9.1		5.8	59.47	4.9	39.14
0.40	24.0	10.4		6.7	76.13	5.6	50.11
0.50	30.0	13.1		8.3	115.04	7.0	75.72
0.60	36.0	15.6		10.0	161.18	8.4	106.1
0.70	42.0	18.2		11.7	214.37	9.8	141.11
0.80	48.0	20.8		13.4	274.44	11.2	180.58

NOTE: Shaded areas of chart indicate where velocities exceed five feet per second. Use with caution.

Head Loss Per 100' of polyethylene tubing (PSI/100')

Catalogs & Specification Sheets

Specification sheets and catalogs are available to assist in the design and planning process. These documents are also available on our website in PDF format at www.digcorp.com.

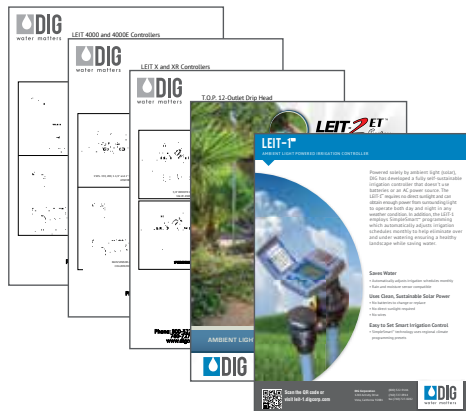

How to specify	
Model	Description
26-405	Specifications • LEIT 4000
26-406	Specifications • LEIT X and XRC
26-407	Specifications • TOP
26-701	Excel dripline with check valve
26-702	Excel dripline
26-703	LEIT 2 ET
41-014	Specification drawings CD
41-021	Dripline cut sheet
41-030	LEIT 2 ET brochure
41-051	LEIT 1 cut sheet

Warranty

DIG Corporation warrants to its customers who have purchased DIG professional irrigation products from an authorized DIG distributor to be free from original defects in material and workmanship under normal uses from the date of original manufacture for a period of:

- LEIT 1 and LEIT 2 ET systems and accessories: Three years
- Controllers, solenoids, actuators and accessories: Three years
- Filters, drip irrigation and accessories: Three years
- Excel dripline, Excel LFPB, Micro-Line dripline and polyethylene tubing: Five years
- LEIT 4000, LEIT X, LEIT XRC, LEIT MultiPro and LEIT Master Handset: Four years

Limited Warranty

DIG Corporation warrants that if any apparent defect arises under normal use and service in the DIG product within the warranty period, DIG at its sole discretion, shall have the option to repair or replace part or all of the original product, free of charge after return of such product at user expense, authorized in writing by DIG Corporation. If a product is replaced, the replacement product will be covered for the remainder of the warranty period dating from the original purchase. This warranty applies only to the DIG Corporation professional irrigation products (excluding the LEIT 4000, LEIT X, LEIT XRC, LEIT MultiPro and LEIT Master Handset), which are installed as specified and used for irrigation purposes. This warranty applies only to products, which have not been altered, modified, damaged, misused nor misapplied. This warranty does not cover products adversely affected by the system into which the products are incorporated, including improperly designed, installed, operated, or maintained systems. This warranty does not apply to blockage of solenoids, valves, dripline, drippers and micro sprinklers due to use of water containing corrosive chemicals, electrolytes, sand, dirt, silt, rust, scale, algae, bacterial slime or other organic contaminants. Tampering with a product (including, but not limited to attempting to disassemble a LEIT controller) will void any warranty the product might otherwise be eligible for. In no event shall DIG's liability exceed the selling price of the product. DIG is not liable for consequential, incidental, indirect or special damages, including loss, loss of energy or water, cost of substitute equipment or services, property damage, loss of use or loss of profits; nor is DIG liable for economic losses, consequential damages or damage to property arising out of installer's negligence or based on strict liability in tort. The user and/or trade customer agrees to the limitations and exclusions of liability of this warranty by purchase or use of DIG products. No representative, agent, distributor or other person has the authority to waive, alter, or add to the printed provisions of this

warranty, or to make any representation of warranty not contained here. Some states do not permit the exclusion or limitation of incidental or consequential damages or of implied warranties. Therefore, some of the above exclusions or limitations may not apply to you. This warranty on DIG professional irrigation products is given expressly and in place of all other expressed or implied warranties of merchantability and fitness for a particular purpose, and this warranty is the only warranty on the professional irrigation products made by DIG Corporation.

DIG Corporation LEIT 4000, LEIT X, LEIT XRC, LEIT MultiPro and LEIT Master exclusive warranty details.

Under this warranty, provided that all installation, start-up and operation responsibilities have been properly executed, DIG CORPORATION will repair or replace, at DIG's option, any part found to be defective under normal recommended use within the stated warranty. Repairs and/or replacements at DIG's expense must be authorized through the Return Agreement process (RA) prior to the repair or replacement begins. Repair of damaged units not otherwise within warranty may be refused or done at a reasonable cost or charge at the option provided by DIG CORPORATION

This warranty does not cover damages resulting from misuse, natural disasters (including lightning), neglect, modification, improper installation or subsection to line pressure in excess of normal irrigation system operation. This warranty shall extend only to the original purchaser of the product. This warranty shall not cover any malfunction of the product if used with a high voltage battery such as 24VAC solenoid testers or any tester that has more than 9 volts DC. The product is intended solely for irrigation purposes. Any use of the product for a purpose other than irrigation voids this warranty.

Repaired or replaced units will be shipped prepaid to the name and address supplied with the unit returned under the warranty, with up to four weeks for diagnostics, repairs and/or shipping time.

In addition DIG extends a limited warranty for an additional one year (1) to cover the costs of replacing components that may be affected by normal wear and tear at the following fees:

LEIT 4000 PVM, Lense Software, Capacitors, Key Pad, Display	\$189.99
LEIT X PVM Lense Software, Capacitors, Key Pad, Display	\$269.99
LEIT XRC PVM, Lense Software, Capacitors, Key Pad, Display	\$289.99

© Copyright 2021 DIG Corporation.
All rights reserved. LEIT, LEIT Link name and logo are registered trademarks and LEIT X, LEIT XRC and DIG logo are tradenames of DIG corporation.



1210 Activity Drive • Vista, California 92081-8510
800.322.9146 • 760.727.0914 • fax 760.727.0282
www.digcorp.com

©2021 All Rights Reserved. Printed in USA | Catalog 41-008
We at DIG strongly believe in recycling. Please recycle.